

		DIFFUSER CODE - HOLES
FLOW L/MIN	10 - 12	DF0504 - 2x3.00
	12 - 15	DF0508 - 3x3.00
	15 - 18	DF0512 - 4x3.00
	18 - 20	DF0516 - 6x3.00
	20 - 25	DF0520 - 8x3.00
	25 - 35	DF0524 - 12x3.00
	35 - 45	DF0528 - 12x3.40
	45 - 60	DF0532 - 18x3.40

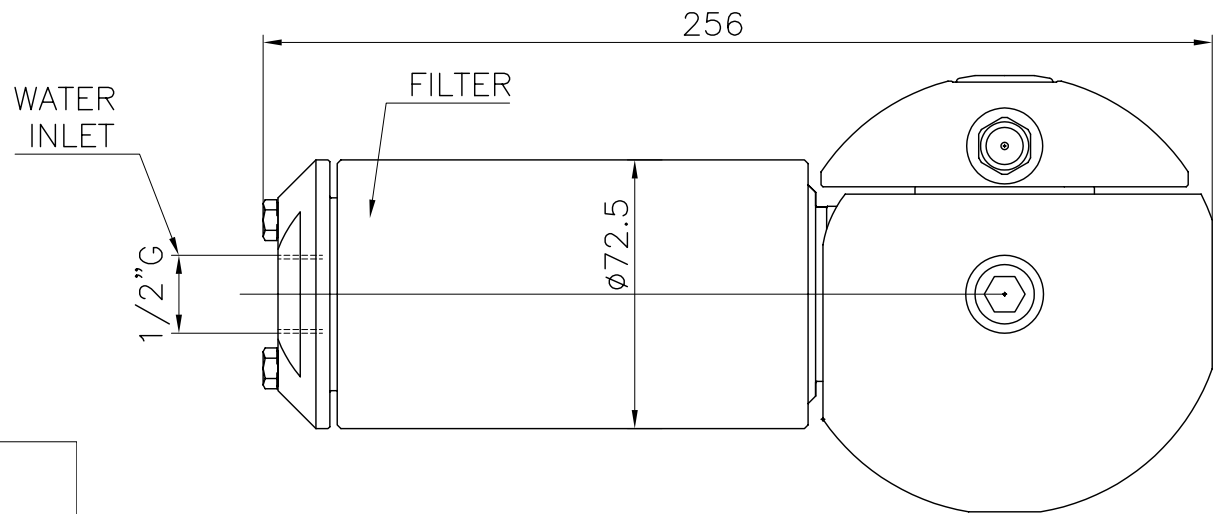

總代理

思沛雅噴霧器材有限公司

TECHNICAL DATA

O.RING	NBR - EPDM - VITON
SLIPPER	PTFE+CARBON FIBRE
BUSHING	AISI 316
FILTER	700 MICRON
NOZZLES POSITIONS	2 - 4
NOZZLES THREAD	1/4"NPT
TESTING NOZZLES	0 x 0000
OPERATING FLOW RANGE	10 - 60 L/min
TESTING FLOW	00 L/min
OPERATING PRESSURE RANGE	5 - 150 bar
TESTING PRESSURE	000 bar
CENTER LINE MIN PASS THROUGH HOLE	123 mm
MANUAL MIN PASS THROUGH HOLE	103 mm
MAX OPERATING TEMPERATURE	90 °C
MATERIAL	INOX AISI 316
CONICAL GEARS	FIXED Z=46 ROTATING Z=47
MODULE	1
ROTATION SPEED RANGE	15 TO 25 RPM
TESTING DIFFUSER CODE	DF0000 (SEE CHART)
FULL CYCLE	47 ROTATIONS
FULL CYCLE TIME	2.4 min AT 20 RPM
WEIGHT	3.9 KG

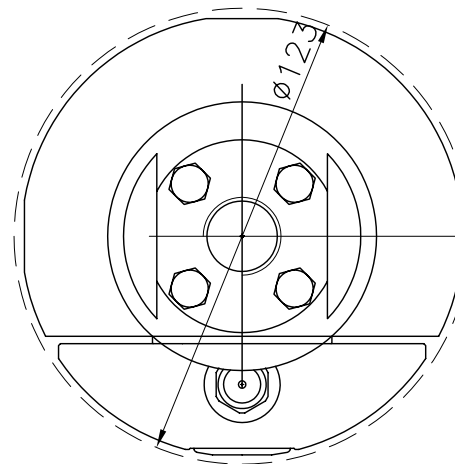

CENTER LINE

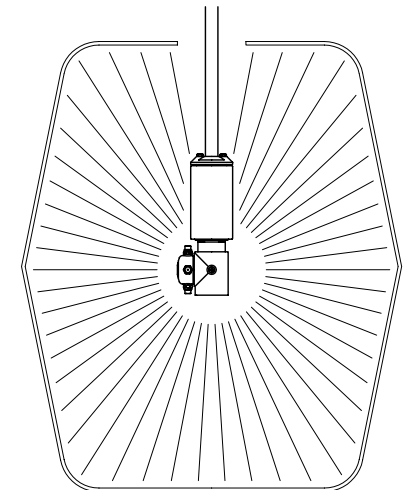

RUGOSITA' (UNI 4600)	MODIFICA	1	2	3	4	5	
	FOGLIO						
GREZZO	DATA						
	TOLLERANZE GENERALI classe m UNI-EN 22768/1	0÷6	6÷30	30÷120	120÷400	400÷1000	1000÷2000
SGROSS.		±0.1	±0.2	±0.3	±0.5	±0.8	±1.2
		NOTE:					
FINITURA		DESCRIZIONE: RW190-A_TK.01					
		APPLICATION DRAWING					
RETTIFICA							

Bokondi	
CLEANING HEADS	
MONTECCHIO E. (RE) - ITALY	
DISEGN.: CR	CONTR.: DM
DATA: 01.06.2012	MOD.
SCALA	
1:2	A4 0
CODICE:	
RW190A-TK	