

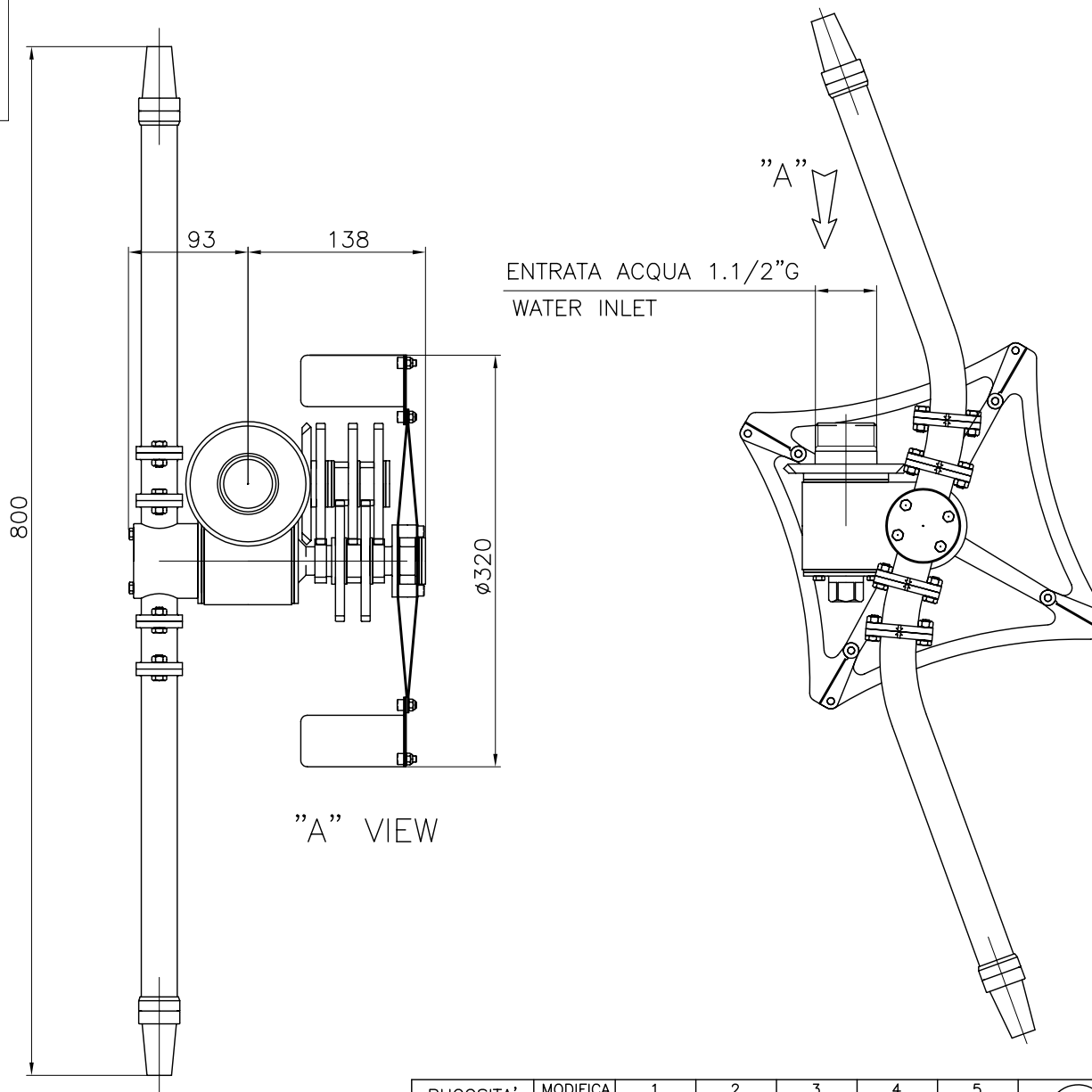

MAX FLOW	600 L/min.
MAX PRESSURE	10 bar
NOZZLES POSITIONS	2
NOZZLES SIZE	7.5-11-14-15.5 mm
SHORT CICLE TIME	4.7 to 9.4 min.
FULL CICLE TIME	14.1 to 28.2 min.
DRIVE	REACTION
ROTATION SPEED	5 to 10 rpm
SPEED CONTROL	AERODYNAMIC
MATERIAL	INOX AISI 316
BUSHING MATERIAL	PEEK
MIN PASS THROUGH HOLE	300 mm
WEIGHT	7.5 Kg.

PORTATA MAX	600 litri/min.
PRESSIONE MAX	10 bar
N° UGELLI	2
DIAMETRI UGELLI	7.5-11-14-15.5 mm
TEMPO CICLO BREVE	da 4.7 a 9.4 min.
TEMPO CICLO COMPLETO	da 14.1 a 28.2 min.
MOTO	REAZIONE
VELOCITA' ROTAZIONE	da 5 a 10 giri/min.
CONTROLLO VELOCITA'	AERODINAMICO
MATERIALE TESTA	INOX AISI 316
MATERIALE BOCCOLE	PEEK
FORO MINIMO PASSAGGIO	300 mm
PESO	7.5 Kg.



"A" VIEW

RUGOSITA' (UNI 4600)	MODIFICA	1	2	3	4	5	
	FOGLIO						
GREZZO	DATA						
	TOLLERANZE GENERALI classe m UNI-EN 22768/1	0÷6	6÷30	30÷120	120÷400	400÷1000	1000÷2000
SGROSS.		±0.1	±0.2	±0.3	±0.5	±0.8	±1.2
FINITURA	NOTE:						
RETTIFICA	MATERIALE:						
	DESCRIZIONE: DISEGNO APPLICAZIONE RW600 INSTALLATION DRAWING RW600						



CLEANING HEADS
MONTECCHIO E. (RE) - ITALY

DISEGN.: CR | CONTR.: DM
DATA: 24.07.08 | MOD.
SCALA: 1:4 | A3 | 0

CODICE: RW600