



總代理

思沛雅噴霧器材有限公司

22205 新北市深坑區北深路三段270巷8號3樓 TEL. 02-8662-6968 FAX. 02-8662-6967

Website : www.sprayernozzle.com.tw E-mail : sales@sprayernozzle.com.tw

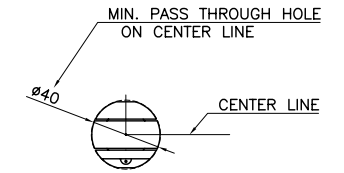
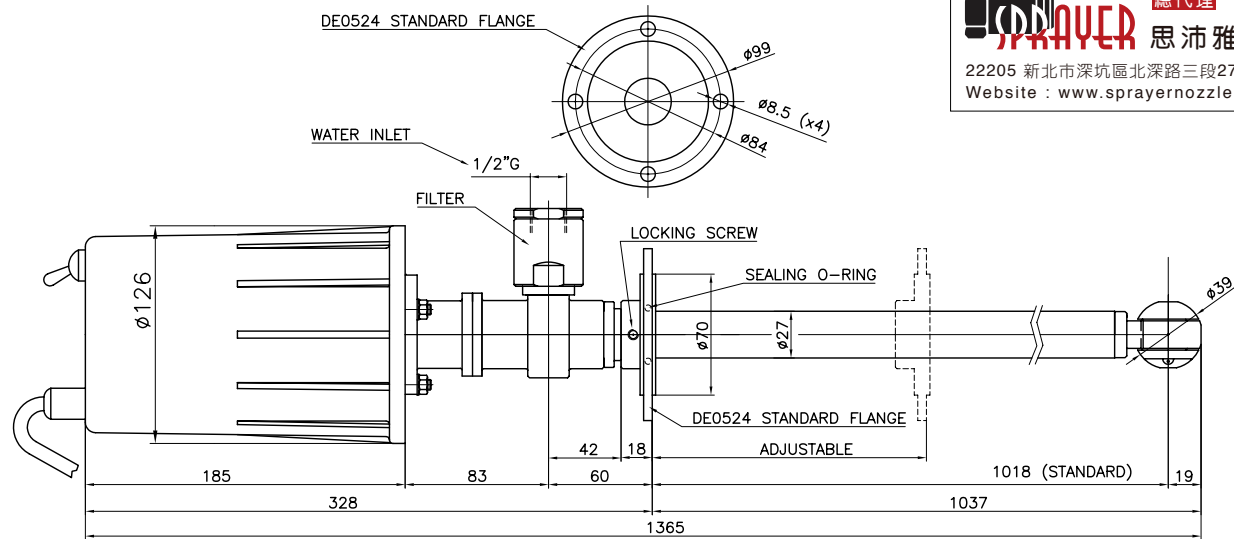

TECHNICAL DATA	
O-RING	NBR - EPDM - VITON
SLIPPER	PTFE+CARBON FIBRE
BUSHING	AISI 316
FILTER	700 MICRON
NOZZLES POSITIONS	2 - 4
NOZZLES THREAD	SPECIAL XB 030
TESTING NOZZLES	0 x DIA. 00.0
OPERATING FLOW RANGE	0 - 30 L/min
TESTING FLOW	00 L/min
OPERATING PRESSURE RANGE	0 - 200 bar
TESTING PRESSURE	000 bar
CENTER LINE MIN PASS THROUGH HOLE	40 mm
MANUAL MIN PASS THROUGH HOLE	40 mm
PIPE LENGHT	1018 mm (STANDARD)
MAX OPERATING TEMPERATURE	90 °C
MATERIAL	INOX AISI 316
CONICAL GEARS	FIXED Z=23 ROTATING Z=25
MODULE	1
FULL CYCLE	25 ROTATIONS
FULL CYCLE TIME	1.5 min
ELECTRIC MOTOR	BB0015
ELECTRIC MOTOR VOLT	24V AC/DC
WEIGHT	7.5 KG

BE0030 DN 65  
DIN 11851-52 NUT

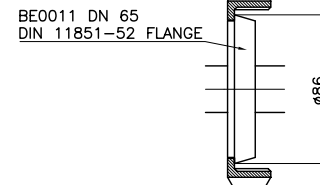

BE0032 DN 80  
DIN 11851-52 NUT

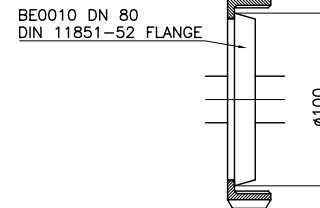

BE0014 3"  
TRI-CLAMP FLANGE

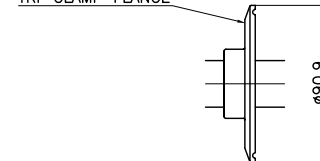

BE0015 4"  
TRI-CLAMP FLANGE

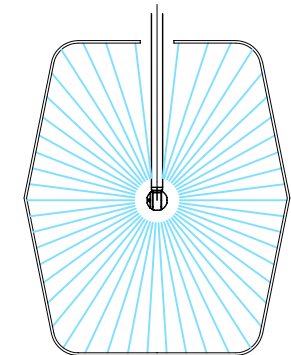
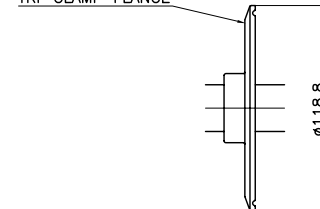

RUGOSITA' (UNI 4600)	MODIFICA	1	2	3	4	5	 CLEANING HEADS MONTECCHIO E. (RE) - ITALY
		FOGLIO DATA	XXXX				
GREZZO	TOLLERANZE GENERALI classe m UNI-EN 22768/1	0±6	6±30	30±120	120±400	400±1000	1000±2000
SGROSS.		±0.1	±0.2	±0.3	±0.5	±0.8	±1.2
FINITURA	DESCRIZIONE: XB 031 E APPLICATION DRAWING						DISEGN.: CR   CONTR.: DM DATA: 06.07.09 MOD.
RETTIFICA							SCALA 1:3   A3   0
							CODICE: XB 031 E