



總代理

思沛雅噴霧器材有限公司

22205 新北市深坑區北深路三段270巷8號3樓 TEL. 02-8662-6968 FAX. 02-8662-6967

Website : www.sprayernozzle.com.tw E-mail : sales@sprayernozzle.com.tw

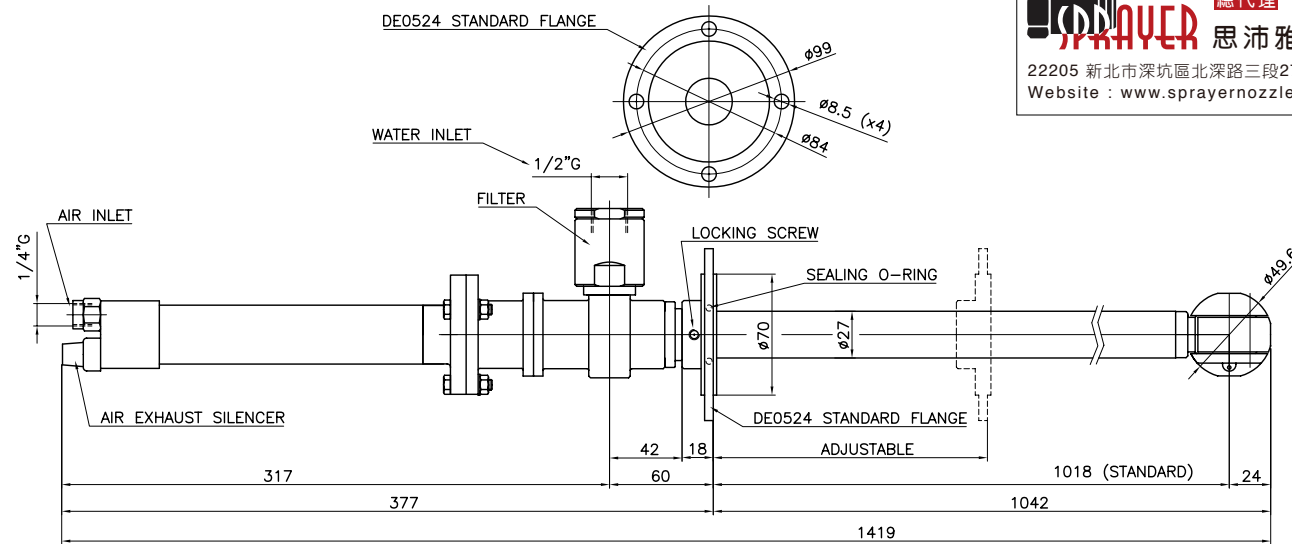

ROTATION SPEED AIR PRESSURE AND CONSUMPTION		
19 RPM	1 bar	155 L/min
28 RPM	2 bar	230 L/min
33 RPM	3 bar	275 L/min
37 RPM	4 bar	320 L/min
40 RPM	5 bar	360 L/min
51 RPM	6 bar	395 L/min

TECHNICAL DATA	
O-RING	NBR - EPDM - VITON
SLIPPER	PTFE+CARBON FIBRE
BUSHING	AISI 316
FILTER	700 MICRON
NOZZLES POSITIONS	2 - 4
NOZZLES THREAD	SPECIAL XB 060
TESTING NOZZLES	0 x DIA. 00.0
OPERATING FLOW RANGE	0 - 60 L/min
TESTING FLOW	00 L/min
OPERATING PRESSURE RANGE	0 - 200 bar
TESTING PRESSURE	000 bar
CENTER LINE MIN PASS THROUGH HOLE	50 mm
MANUAL MIN PASS THROUGH HOLE	50 mm
PIPE LENGTH	1018 mm (STANDARD)
MAX OPERATING TEMPERATURE	90 °C
MATERIAL	INOX AISI 316
CONICAL GEARS	FIXED Z=29 ROTATING Z=31
MODULE	1
FULL CYCLE	31 ROTATIONS
FULL CYCLE TIME	1 min AT 3 BAR AIR PRESSURE
AIR MOTOR	BA0705 FIAM ML5Z
AIR EXHAUST	WITH SILENCER
ROTATION SPEED	SEE CHART
WEIGHT	7.5 KG

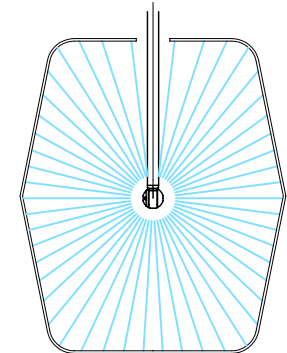
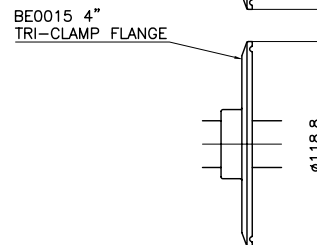
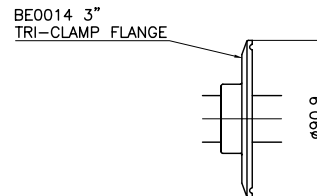
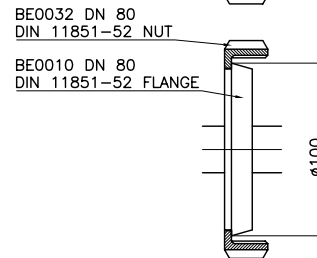
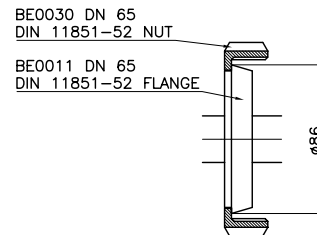

RUGOSITA' (UNI 4600)	MODIFICA	1					2					3					4					5					
		FOGLIO DATA					XXXX XX.XX.XX																				
GREZZO	~ =	TOLLERANZE GENERALI classe m UNI-EN 22768/1																									
SGROSS.	▽ = 3.2/▽	0±6	6±30	30±120	120±400	400±1000	1000±2000																				
FINITURA	▽ = 1.6/▽	±0.1	±0.2	±0.3	±0.5	±0.8	±1.2																				
RETTIFICA	▽ = 0.8/▽	NOTE:																									
DESCRIZIONE: XB 061 P APPLICATION DRAWING		<p>CLEANING HEADS MONTECCHIO E. (RE) - ITALY</p> <p>DISEGN.: CR CONTR.: DM DATA: 06.07.09 MOD. SCALE: 1:3 A3 0</p> <p>CODICE: XB 061 P</p>																									