



總代理

思沛雅噴霧器材有限公司

22205 新北市深坑區北深路三段270巷8號3樓 TEL. 02-8662-6968 FAX. 02-8662-6967

Website : www.sprayernozzle.com.tw E-mail : sales@sprayernozzle.com.tw

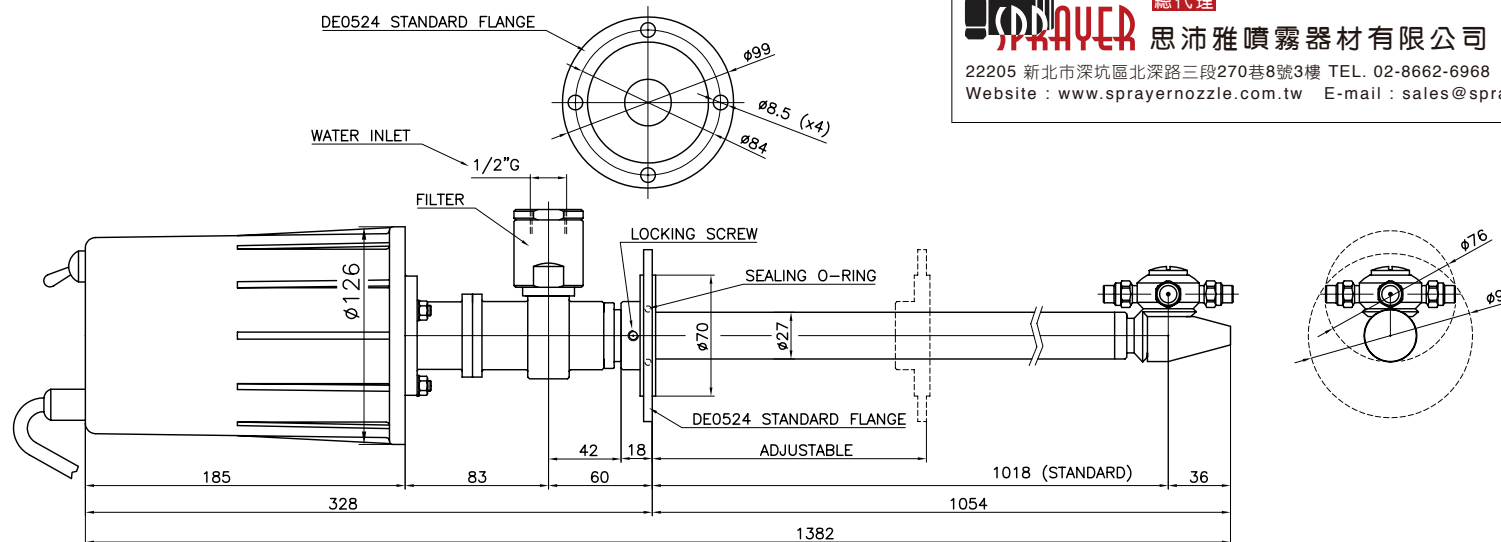

BE0030 DN 65
DIN 11851-52 NUT

BE0011 DN 65
DIN 11851-52 FLANGE

BE0032 DN 80
DIN 11851-52 NUT

BE0010 DN 80
DIN 11851-52 FLANGE

BE0014 3"
TRI-CLAMP FLANGE

BE0015 4"
TRI-CLAMP FLANGE

TECHNICAL DATA				
O.RING	NBR - EPDM - VITON			
SLIPPER	PTFE+CARBON FIBRE			
BUSHING	AISI 316			
FILTER	700 MICRON			
NOZZLES POSITIONS	2 - 4			
NOZZLES THREAD	1/8"NPT			
TESTING NOZZLES	0 x 0000			
OPERATING FLOW RANGE	0 - 60 L/min			
TESTING FLOW	00 L/min			
OPERATING PRESSURE RANGE	0 - 200 bar			
TESTING PRESSURE	000 bar			
CENTER LINE MIN PASS THROUGH HOLE	95 mm			
MANUAL MIN PASS THROUGH HOLE	76 mm			
PIPE LENGHT	1018 mm (STANDARD)			
MAX OPERATING TEMPERATURE	90 °C			
MATERIAL	INOX AISI 316			
CONICAL GEARS	FIXED Z=29 ROTATING Z=31			
MODULE	1			
FULL CYCLE	31 ROTATIONS			
GEARBOX	W/MOTOR	BB0743	BB0743	BB0743
ELECTRIC MOTOR	BB0015	BA0105	BA0102	BA0108
ELECTRIC MOTOR VOLTS	24V AC/DC	48V 50Hz 1ph	230V 50Hz 1ph	400V 50Hz 3ph
ELECTRIC MOTOR AMPS	0.30 A	1.15 A	0.23 A	0.10 A
ROTATION SPEED	17 RPM	14 RPM	14 RPM	14 RPM
FULL CYCLE TIME	1.8 min	2.2 min	2.2 min	2.2 min
WEIGHT	7.5 KG			

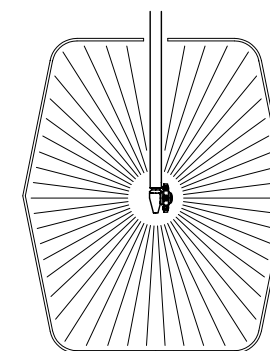

RUGOSITA' (UNI 4600)	MODIFICA	1	2	3	4	5	 CLEANING HEADS MONTECCHIO E. (RE) - ITALY
FOGLIO DATA	XXXX XX.XX.XX						
GREZZO	TOLLERANZE GENERALI classe m UNI-EN 22768/1						SCALA 1:3 A3 0
~ = √	0±6	6±30	30±120	120±400	400±1000	1000±2000	
SGROSS. ∇ = 3.2/√	±0.1	±0.2	±0.3	±0.5	±0.8	±1.2	
FINITURA ∇∇ = 1.6/√	DESCRIZIONE: XC 061 E APPLICATION DRAWING						
RETTIFICA ∇∇∇ = 0.8/√							