

總代理

思沛雅噴霧器材有限公司

22205 新北市深坑區北深路三段270巷8號3樓 TEL. 02-8662-6968 FAX. 02-8662-6967
 Website : www.sprayernozzle.com.tw E-mail : sales@sprayernozzle.com.tw

MAX FLOW	60 L/MIN.
MAX PRESSURE	200 BAR
NOZZLES POSITIONS	2 - 4
NOZZLE THREAD	1/8" G SPECIAL
ELECTRIC MOTOR	56B5-4P-1400RPM-0.09KW-400V-3PH
GEARBOX	CM040U-1:80 RATIO
ROTATION SPEED	18 RPM
WASHING FULL CYCLE TIME	2 MIN.
HEAD MATERIAL	INOX
WEIGHT	12.5 KG.

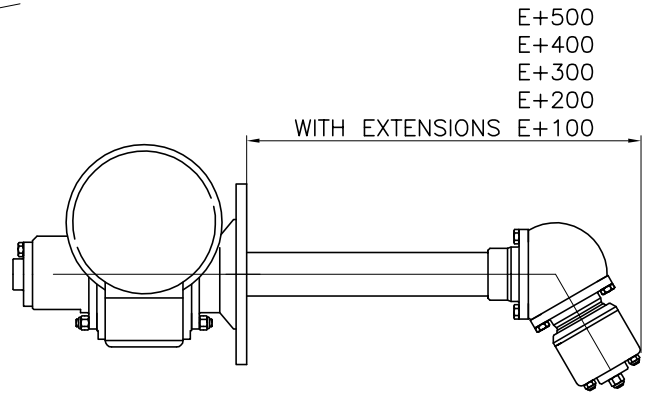
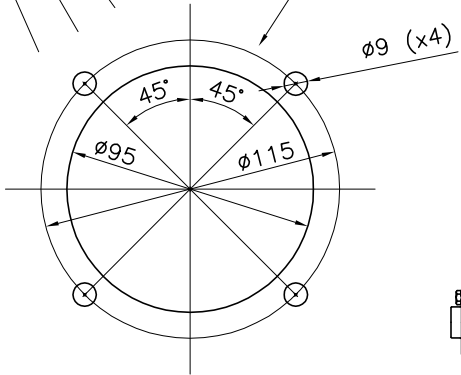

RUGOSITA' (UNI 4600)	MODIFICA	1	2	3	4	5	
	FOGLIO	XXXX					
	DATA	XX.XX.XX					CLEANING HEADS
GREZZO	TOLLERANZE GENERALI classe m UNI-EN 22768/1						MONTECCHIO E. (RE) - ITALY
~ = ✓	0±6	6±30	30±120	120±400	400±1000	1000±2000	DISEGN.: CR CONTR.: DM
SGROSS.	±0.1	±0.2	±0.3	±0.5	±0.8	±1.2	DATA: 06.04.11 MOD.
▽ = 3.2/▽	NOTE:						SCALA
FINITURA	MATERIALE:						1:2 A3 0
▽ = 1.6/▽	DESCRIZIONE: CONCRETE MIXER WASHING HEAD AUTOMATIC PROTECTION VERSION						CODICE:
RETTIFICA							XC 070E PT
▽ = 0.8/▽							