

WATER INLET  
FOUR 90° DIRECTION OPTIONS

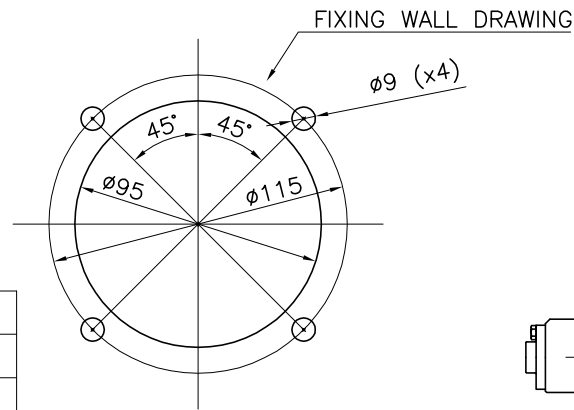

FIXING WALL DRAWING

E+500  
E+400  
E+300  
E+200  
WITH EXTENSIONS E+100

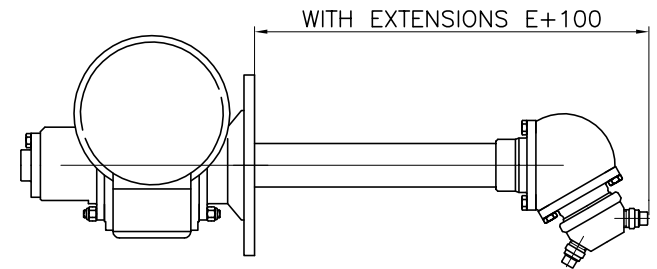

MAX FLOW	60 L/MIN.
MAX PRESSURE	200 BAR
NOZZLES POSITIONS	4
NOZZLE THREAD	1/4"G
ELECTRIC MOTOR	56B5-4P-1400RPM-0.09KW-400V-3PH
GEARBOX	CM040U-1:80 RATIO
ROTATION SPEED	18 RPM
WASHING FULL CYCLE TIME	2 MIN.
HEAD MATERIAL	INOX+BRASS
WEIGHT	12.5 KG.

RUGOSITA' (UNI 4600)	MODIFICA	1	2	3	4	5	 CLEANING HEADS MONTECCHIO E. (RE) - ITALY
GREZZO	FOGLIO DATA	XXXX					
SGROSS.	TOLLERANZE GENERALI classe m UNI-EN 22768/1						DEIGN.: CR   CONTR.: DM DATA: 11.02.11   MOD.
FINITURA	0±6   6±30   30±120   120±400   400±1000   1000±2000 ±0.1   ±0.2   ±0.3   ±0.5   ±0.8   ±1.2						
RETTIFICA	NOTE:						SCALE 1:2   A3   0
	DESCRIZIONE: CONCRETE MIXER WASHING HEAD STETTER VERSION						
	MATERIALE:						CODICE: XC 070E cm3