

P Ugelli a fessure verticali

Filter nozzles with vertical slots



- Adatto per filtrazione sabbia e antracite
- Di facile pulizia mediante controlavaggio
- Ampia gamma di filetti e codoli
- Economico

- Suitable for sand and anthracite filters
- Easily cleaned by backwash
- Wide set of threads and stems
- Inexpensive

Materiale

Material



Modello Model	Fessura Slot width mm	N° Fessure Slots n°	Area mm²	Colore cupola Head colour
P	0,25	30	165	
	0,50	26	286	
	0,80	20	352	
	1,00	20	440	
	2,00	18	774	
	3,00	12	684	

Ugello con certificazione ACS/MOCA prodotto PP Naturale (Bianco) - Ugello in PPFV30% prodotto Naturale (Avorio) - Ugello in PVDF prodotto Naturale (Bianco)
Nozzle with ACS/MOCA certification produced PP Natural (White) - Nozzle in PPFV30% produced Natural (Ivory) - Nozzle in PVDF produced Natural (White)

ORDINE - ORDER

Modello Model	Fessura Slot width	Filetto Thread	ID mm	L1 mm	L2 mm	L3 mm	Materiale Material
P	0,25	15/16"W	16	50	140	0	PP

Ugello mod. PTL con tassello espansione preassemblato
Nozzle mod. PTL with preassembled expansion bolt

Scheda tecnica
a pag. 26
Data sheet
pag. 26



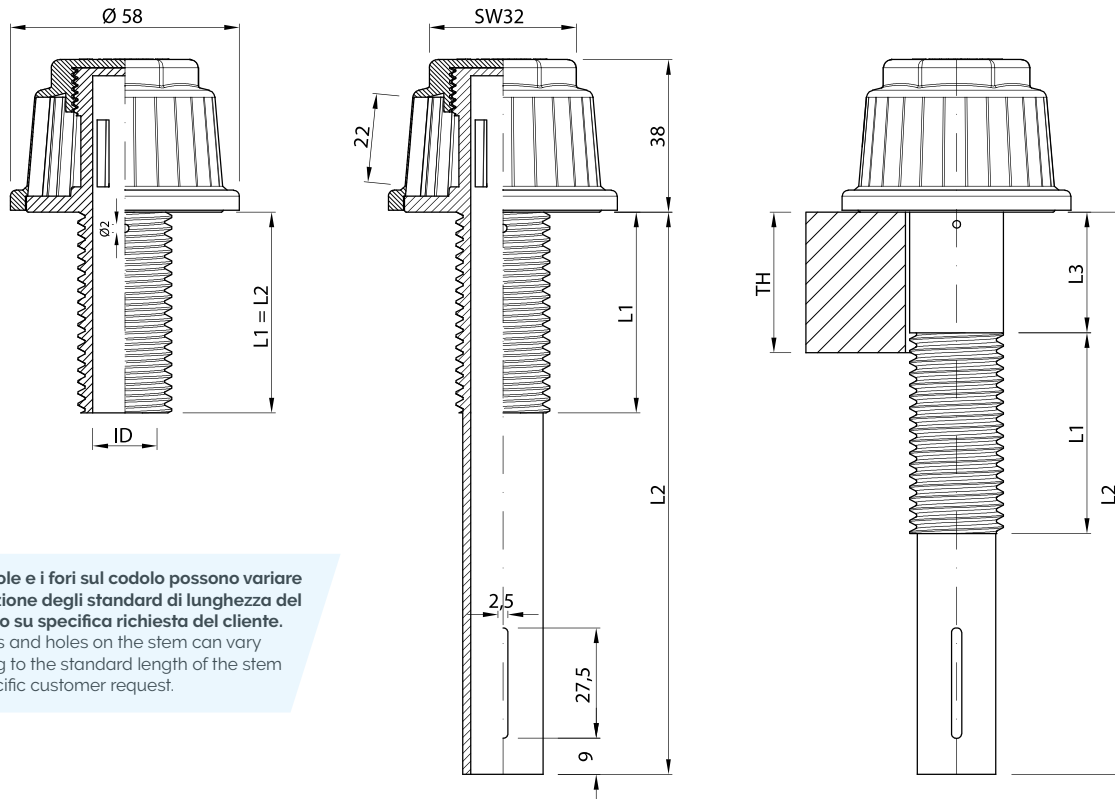

Le asole e i fori sul codolo possono variare in funzione degli standard di lunghezza del codolo o su specifica richiesta del cliente.
The slots and holes on the stem can vary according to the standard length of the stem or on specific customer request.

Filetto Thread	mm	Col. codolo Stem col.	ID Standard mm	Area codolo Stem area mm ²	L1 - Lunghezza filetto Thread length mm	L2 - Lunghezza codolo Stem length mm	L3 - Scostamento Deviation mm
3/8" G	16,5	■	10	78	15	... 50, 80, 100	0, 5, +5 ...
1/2" G	20,9	■	14	154	15, 20, 30, 35, 50	... 50, 80, 100, 120, 140, +5 ... 300	0, 5, +5 ...
3/4" G	26,4	■	16	200	15, 20, 30, 50	... 50, 80, 100, 120, 140, +5 ... 400	0, 5, +5 ...
1" G	33,2	■	21	346	15, 35	... 50, 80, 100, 120, 140, +5 ... 400	0, 5, +5 ...
7/8" W	22,2	■	14	154	30	... 50, 80, 100, 120, 140, +5 ... 400	0, 5, +5 ...
15/16" W	23,8	■	16	200	20, 30, 40, 50, 70	... 50, 80, 100, 120, 140, +5 ... 400	0, 5, +5 ...
1" W	25,4	■	16	200	20, 25, 30, 50	... 50, 80, 100, 120, 140, +5 ... 400	0, 5, +5 ...
1 1/4" W	31,7	■	21	346	30, 50	... 50, 80, 100, 120, 140, +5 ... 400	0, 5, +5 ...
M20 x 2.5	20	■	14	154	20, 50	... 50, 80, 100, 120, 140, +5 ... 400	0, 5, +5 ...
M24 x 3.0	24	■	16	200	20, 30, 40, 50	... 50, 80, 100, 120, 140, +5 ... 400	0, 5, +5 ...
M30 x 3.5	30	■	21	346	20, 30, 50	... 50, 80, 100, 120, 140, +5 ... 400	0, 5, +5 ...

Disponibili anche M38x4, M27x3, M18x1.5 ... è possibile creare ogni configurazione su specifica richiesta del cliente.
Available also M38x4, M27x3, M18x1.5 ... It's possible to create any configuration on specific customer need.

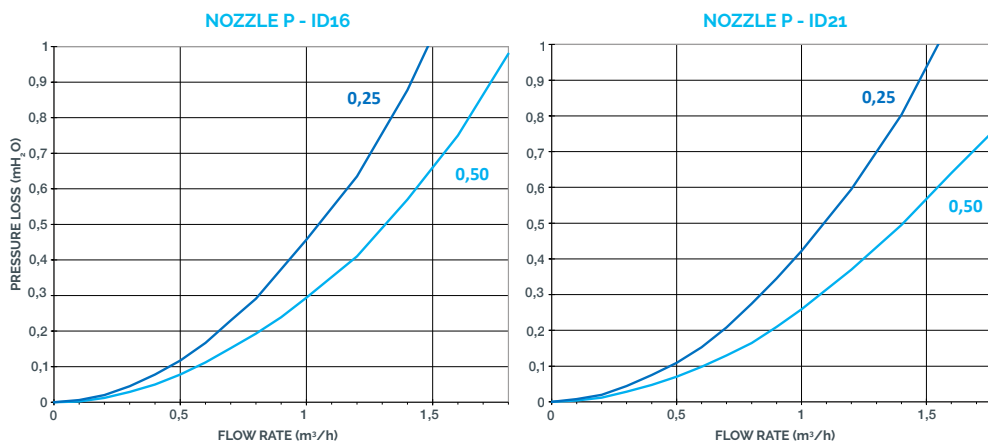

NOTE
Su richiesta è possibile fornire la Curva di Perdita di Carico per tutta la gamma di ugelli Ilmap.
The Pressure Loss Curve of the Ilmap Nozzles range can be supplied on demand.