

大噴量設計 / 內部混合型噴頭

壓力式

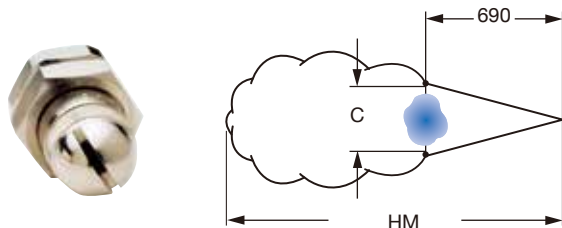

大噴量型二流體噴嘴，共有四種不同的噴霧形狀與噴霧角度，最大噴量更可達到1158L/hour，針對需要大噴量的場合，是最佳的選擇。

典型應用

廢氣急冷塔、煙道洗滌、垃圾掩埋場加濕鎮塵、礦場加濕鎮塵

噴頭型號	空氣壓力(bar)														參考數據					
	噴霧量		氣體消耗量		噴霧量		氣體消耗量		噴霧量		氣體消耗量		噴霧量		氣體消耗量		空氣壓力	液體壓力	參考噴幅	
	l/hour	NI/min	l/hour	NI/min	l/hour	NI/min	l/hour	NI/min	l/hour	NI/min	l/hour	NI/min	l/hour	NI/min	C	HM				
SUL 3316 Ln XMW 5201 An XMW 4110	-	-	-	-	-	-	2.1	213	176	3.1	316	214	4.2	238	351	2.1	2	690	6700	
	-	-	-	-	-	-	2.3	127	249	3.2	195	292	4.3	154	439	3.2	3	690	7300	
	-	-	-	-	-	-	-	-	-	3.4	107	371	4.5	100	521	4.3	4	690	8500	
SUL 3192 Ln XMW 5201 An XMW 4111	0.6	102	184	1.1	215	153	2.5	185	355	3.7	192	560	5.0	230	830	0.7	0.4	650	6100	
	0.7	57	230	1.3	124	230	2.7	146	410	3.9	150	620	5.3	158	940	1.3	1.0	670	7900	
	0.9	32	280	1.4	84	280	2.8	112	465	4.0	119	680	5.6	108	1080	2.8	2.0	650	6400	
	-	-	-	3.0	86	520	4.2	86	770	-	-	-	-	-	-	4.0	3.0	670	7300	
	-	-	-	3.1	65	580	4.6	51	910	-	-	-	-	-	-	5.3	4.0	690	8200	
	-	-	-	-	-	-	-	-	-	-	-	-	-	-	-	-	-	-	-	-
SUL 3300 Ln XMW 5201 An XMW 4112	0.7	129	325	1.7	182	540	3.1	265	810	4.3	350	1000	-	-	-	0.9	0.4	690	7900	
	0.9	82	370	1.8	143	590	3.2	215	860	4.6	260	1080	-	-	-	1.7	1.0	660	7300	
	1.0	45	415	-	-	-	3.4	173	910	5.0	186	1200	-	-	-	3.4	2.0	660	7000	
	-	-	-	3.5	136	950	-	-	-	-	-	-	-	-	-	4.6	3.0	690	8500	
SUM 3740 Ln XMW 5202 An XMW 4113	0.7	134	315	1.3	320	440	2.1	575	570	3.0	740	710	3.9	840	860	0.7	0.4	910	3400	
	0.9	100	380	1.4	255	520	2.2	505	640	3.1	690	770	4.1	790	930	1.4	1.0	910	4900	
	-	-	-	1.5	200	590	2.4	440	720	3.2	630	840	4.2	740	990	2.5	2.0	810	6100	
	-	-	-	1.7	154	670	2.5	380	790	3.4	570	910	4.4	690	1070	3.4	3.0	740	6700	
	-	-	-	-	-	-	2.7	330	860	3.5	520	980	4.5	650	1140	4.5	4.0	730	7600	
	-	-	-	-	-	-	2.8	275	930	3.7	470	1050	4.6	600	1210	-	-	-	-	
	-	-	-	-	-	-	3.0	235	1010	3.8	420	1120	4.8	550	1280	-	-	-	-	
	-	-	-	-	-	-	3.1	195	1080	3.9	345	1190	4.9	510	1350	-	-	-	-	
	-	-	-	-	-	-	-	-	-	4.1	325	1260	5.1	465	1430	-	-	-	-	
	-	-	-	-	-	-	-	-	-	-	-	-	5.2	425	1490	-	-	-	-	
	-	-	-	-	-	-	-	-	-	-	-	-	5.3	390	1560	-	-	-	-	
	-	-	-	-	-	-	-	-	-	-	-	-	5.5	350	1640	-	-	-	-	
SUB 3230 Ln XMW 5201 An XMW 4101	1.3	34	350	1.7	146	365	3.0	230	510	-	-	-	-	-	-	1.4	0.4	-	6700	
	1.4	25	390	1.8	121	395	3.1	200	550	-	-	-	-	-	-	2.0	1.0	250	7300	
	1.5	20	415	2.0	102	430	3.2	176	590	-	-	-	-	-	-	3.2	2.0	-	8200	
	1.7	15.5	445	2.1	86	460	3.4	154	620	-	-	-	-	-	-	-	-	-	-	
	-	-	-	2.3	72	490	3.5	135	660	-	-	-	-	-	-	-	-	-	-	
	-	-	-	2.4	60	520	3.6	118	700	-	-	-	-	-	-	-	-	-	-	
SUB 3740 Ln XMW 5202 An XMW 4102	0.7	134	315	1.3	320	440	2.1	575	570	3.0	740	710	3.9	840	860	0.7	0.4	230	7000	
	0.9	100	380	1.4	255	520	2.2	505	640	3.1	690	770	4.1	790	930	1.4	1.0	280	6400	
	-	-	-	1.5	200	590	2.4	440	720	3.2	630	840	4.2	740	990	2.5	2.0	250	11300	
	-	-	-	1.7	154	670	2.5	380	790	3.4	570	910	4.4	690	1070	3.4	3.0	250	12500	
	-	-	-	-	-	-	2.7	330	860	3.5	520	980	4.5	650	1140	4.5	4.0	250	14300	
	-	-	-	-	-	-	2.8	275	930	3.7	470	1050	4.6	600	1210	-	-	-	-	
	-	-	-	-	-	-	3.0	235	1010	3.8	420	1120	4.8	550	1280	-	-	-	-	
	-	-	-	-	-	-	3.1	195	1080	3.9	345	1190	4.9	510	1350	-	-	-	-	
	-	-	-	-	-	-	-	-	-	4.1	325	1260	5.1	465	1430	-	-	-	-	
	-	-	-	-	-	-	-	-	-	-	-	-	5.2	425	1490	-	-	-	-	
SUM 3184 Ln XMW 5201 An XMW 4120	-	-	-	1.8	154	590	3.4	184	950	-	-	-	-	-	-	2.0	1.0	910	5800	
	-	-	-	2.0	119	640	3.5	157	1010	-	-	-	-	-	-	3.5	2.0	970	7000	
	-	-	-	2.1	93	690	3.7	133	1060	-	-	-	-	-	-	-	-	-	-	
	-	-	-	3.8	112	1110	-	-	-	-	-	-	-	-	-	-	-	-	-	
SUQ 3740 Ln XMW 5202 An XMW 4121	0.7	134	315	1.3	320	440	2.1	575	570	3.0	740	710	3.9	840	860	0.7	0.4	1190	4000	
	0.9	100	380	1.4	255	520	2.2	505	640	3.1	690	770	4.1	790	930	1.4	1.0	2110	4600	
	-	-	-	1.5	200	590	2.4	440	720	3.2	630	840	4.2	740	990	2.5	2.0	2080	5200	
	-	-	-	1.7	154	670	2.5	380	790	3.4	570	910	4.4	690	1070	3.4	3.0	2160	5800	
	-	-	-	-	-	-	2.7	330	860	3.5	520	980	4.5	650	1140	4.5	4.0	2260	6400	
	-	-	-	-	-	-	2.8	275	930	3.7	470	1050	4.6	600	1210	-	-	-	-	
	-	-	-	-	-	-	3.0	235	1010	3.8	420	1120	4.8	550	1280	-	-	-	-	
	-	-	-	-	-	-	3.1	195	1080	3.9	345	1190	4.9	510	1350	-	-	-	-	
	-	-	-	-	-	-	-	-	-	4.1	325	1260	5.1	465	1430	-	-	-	-	
	-	-	-	-	-	-	-	-	-	-	-	-	5.2	425	1490	-	-	-	-	
	-	-	-	-	-	-	-	-	-	-	-	-	5.3	390	1560	-	-	-	-	
	-	-	-	-	-	-	-	-	-	-	-	-	5.5	350	1640	-	-	-	-	

廣角實心圓錐形

實心圓錐形

扇形

液體壓力 (bar) 0.35 1.0 2.0 3.0 4.0

壓力式

外部混合型噴頭 \ 扇形

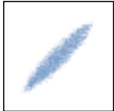

噴霧斷面

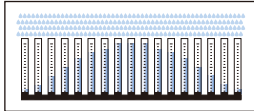

流量分布：標準凸形分布

噴頭型號	空氣壓力(bar)										參考數據			
	0.2		0.35		0.5		0.7		1.0		空氣壓力	液體壓力	參考噴幅	
Ln 液體帽型號 An 空氣帽型號	噴霧量 l/hour	氣體消耗量 NI/min	噴霧量 l/hour	氣體消耗量 NI/min	噴霧量 l/hour	氣體消耗量 NI/min	噴霧量 l/hour	氣體消耗量 NI/min	噴霧量 l/hour	氣體消耗量 NI/min			C	HM
SUM 4145	2.1	877	2.8	1075	3.2	1174	3.9	1358	5.6	1839	2.5	0.2	520	5800
	2.4	962	3.2	1174	3.5	1273	4.2	1457	6.0	1952	3.5	0.4	550	6700
	2.8	1075	3.5	681	3.9	795	4.9	1641	6.3	2037	3.9	0.5	580	7020
	3.2	1174	3.9	1358	4.2	1457	5.3	1754	6.6	2122	4.9	0.7	610	7630
	4.2	1457	4.6	1556	4.9	1641	6.0	1839	7.0	2207	6.3	1.0	660	8850
Ln XMW 5201 An XMW 4135														

壓力式

內部混合型噴頭 \ 空心圓錐形

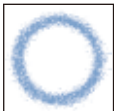

噴霧斷面

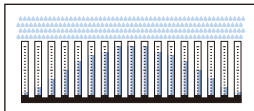

流量分布：標準凸形分布

噴頭型號	空氣壓力(bar)														
	0.7		1.4		2.1		2.8		4.2						
Ln 液體帽型號 An 空氣帽型號	噴霧量 l/hour	氣體消耗量 NI/min	噴霧量 l/hour	氣體消耗量 NI/min	噴霧量 l/hour	氣體消耗量 NI/min	噴霧量 l/hour	氣體消耗量 NI/min	噴霧量 l/hour	氣體消耗量 NI/min					
SUZ 3460	1.0	213.0	345	1.7	394	453	2.5	439	634	3.4	462	787	5.0	484	1138
	1.1	145.0	418	1.8	324	526	2.7	372	702	3.5	416	843	5.2	439	1197
	1.3	97.6	575	2.0	275	574	2.8	322	750	3.7	372	891	5.3	409	1254
	1.4	59.0	538	2.1	207	642	3.0	277	818	3.8	325	956	5.5	366	1310
	-	-	-	2.3	159	702	3.1	272	874	3.9	282	1019	5.6	325	1367
	-	-	-	2.4	116	758	3.2	188	931	4.1	250	1084	5.8	297	1429
	-	-	-	2.5	93	829	3.4	145	990	4.2	209	1135	5.9	257	1486
	-	-	-	2.7	27	900	3.5	114	1050	4.4	168	1189	6.0	232	1551
	-	-	-	-	-	-	-	-	-	4.5	141	1259	6.3	182	1670
	-	-	-	-	-	-	-	-	-	4.6	77	1296	-	-	-
	Ln XMW 5202 An XMW 4146														

虹吸式

內部混合型噴頭 \ 實心圓錐形

噴頭型號
Ln 液體帽型號 An 空氣帽型號

空氣壓力(bar)

空氣壓力 (bar)	空氣流量 (NI/min)								參考數據	
	液體流量 (l/hour)								空氣壓力	HM
0.7	360	-	-	-	40	-	-	-	1.5	6100
1.5	570	-	-	-	97	64.0	-	-	2.0	6700
2.0	660	-	-	-	117	90.0	-	-	3.0	7300
3.0	870	-	260.0	225	150	123.0	90	-	3.5	7900
3.5	990	300	265.0	235	163	133.0	104	-	4.0	8800
4.0	1100	305	270.0	240	170	143.0	115	-	5.0	9800
5.0	1300	315	280.0	250	183	157.0	129	53	5.6	10700
5.6	1450	320	290.0	255	188	164.0	136	62	-	-

450	300	150	100	200	300	600
Gravity head (mm)			Suction head (mm)			

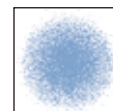

噴霧斷面

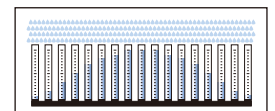













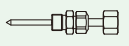

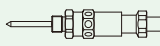
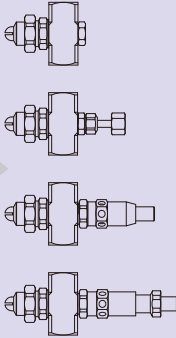
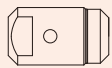

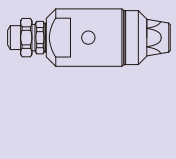



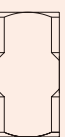

流量分布：標準凸形分布

SUC 2230
Ln XMW 5201 An XMW 4145

請參照下表，依噴嘴功能及需求條件組合完整的二流體噴嘴型號

編碼方式說明

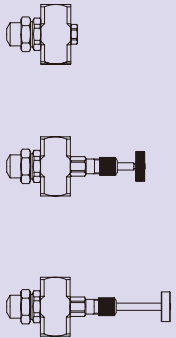
1. 選擇搭配本體形式	2. 選擇適合的噴頭形式 螺帽 空氣噴嘴 液體噴嘴 密封墊圈	3. 選擇噴嘴材質	4. 選擇噴嘴附加功能 MW系列功能代碼一碼 MX系列功能代碼二碼	5. 選擇噴嘴接頭形式	完成二流體噴嘴
1/4" MW 標準本體 	標準實心圓錐形 P.12 壓力式 內部混合型  廣角實心圓錐形 P.13 壓力式 內部混合型  扇形 P.14 壓力式 內部混合型 	B1 / SUS303 B3 / SUS316 D1 / PVC E6 / LUCITE T8 / 黃銅鍍鎳	A / 塞頭(基本型)  B / 噴量調整針  C / 清潔針  D / 清潔針及噴量調整功能 	B / BSP Female (EU) N / NPT Female (US)	
1/4" MX 自動噴槍本體 標準型 	實心圓錐形 P.15 虹吸式 內部混合型  扇形 P.15 虹吸式 內部混合型 	B1 / SUS303 B3 / SUS316 T8 / 黃銅鍍鎳	S / 標準型 U / 標準型 單一氣源入口 A / 逆止功能	B / BSP Female (EU) N / NPT Female (US)	
1/8" MX 自動噴槍本體 迷你型 	扇形 P.16 壓力式 外部混合型 	T8 / 黃銅鍍鎳	M / 迷你型 N / 迷你型 單一氣源入口	N / NPT Female (US)	
1/2" MW 大噴量型本體 	廣角實心圓錐形 P.19 壓力式 內混型  實心圓錐形 P.19 壓力式 內混型  扇形 P.19 壓力式 內混型  扇形 P.20 壓力式 外混型  空心圓錐形 P.20 壓力式 內混型  實心圓錐形 P.20 虹吸式 內混型 	B1 / SUS303 B3 / SUS316 D1 / PVC T8 / 黃銅鍍鎳	A / 塞頭(基本型)  B / 噴量調整針  C / 清潔針 	B / BSP Female (EU) N / NPT Female (US)	

洽詢方式說明

範例 MXB 1520 B1SAB

1. 本體形式
MX
 請參閱上表步驟1

2. 二流體噴頭組
B 1520
 請參閱上表步驟2
SUB 1520 → B 1520
 ① 選定《二流體噴頭組》型號SUB 1520
 ② 將SU(Set Up) 移除，使用型號為B 1520。

3. 材質
B1
 請參閱上表步驟3

4. 附加功能
SA
 請參閱上表步驟4
 MW系列功能代碼一碼
 MX系列功能代碼二碼

5. 接頭形式
B
 請參閱上表步驟5

噴嘴零件功能說明 / 依噴嘴功能及需求條件組合完整的二流體噴嘴型號

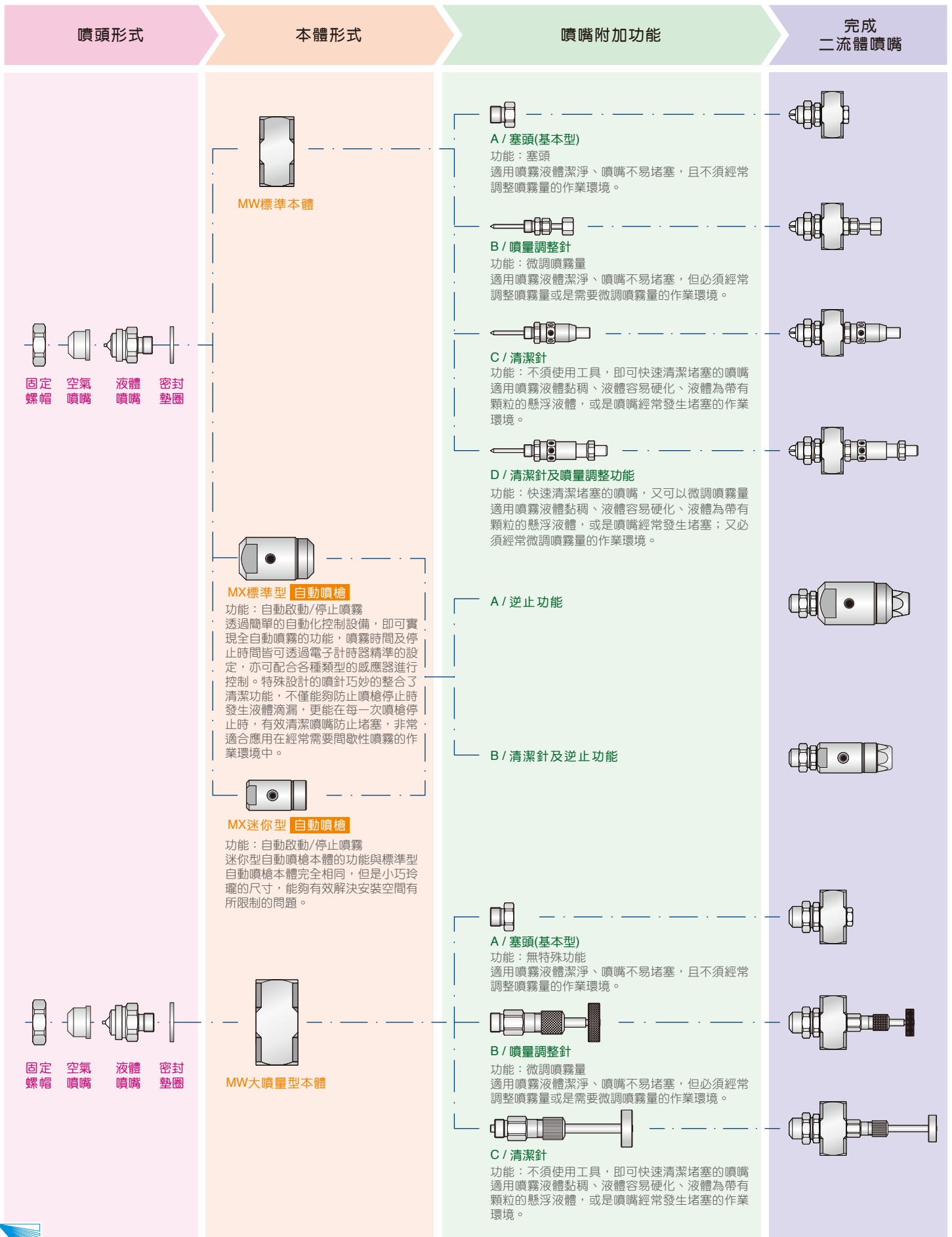

MW二流體噴嘴及MX自動噴槍尺寸圖

□ MW(1/4"標準型)二流體噴嘴 & MX自動噴槍尺寸圖

請先選擇噴嘴本體形式及附加功能，再依噴頭形式對照正確噴嘴尺寸(參照右表尺寸表)

MW標準本體 / 塞頭(基本型)

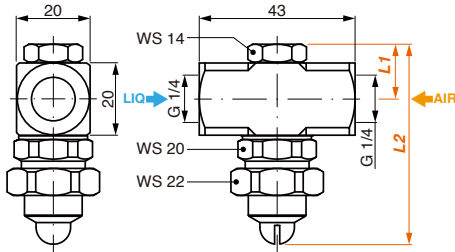

MW標準本體 / 噴量調整針

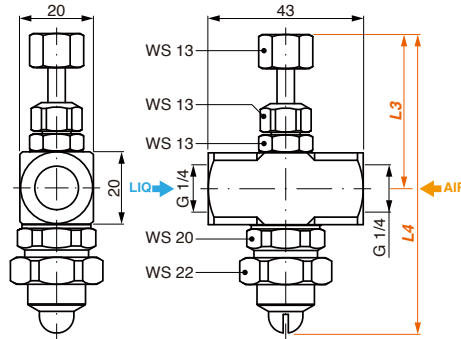

MW標準本體 / 清潔針

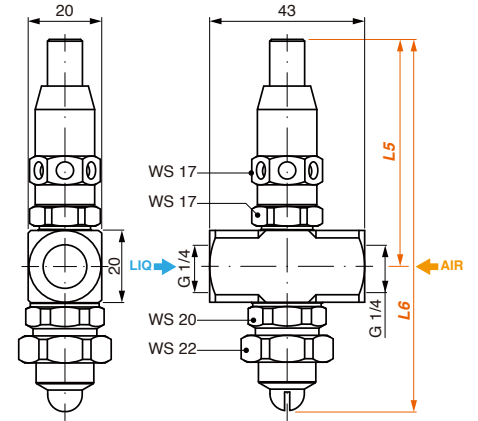

MW標準本體 / 噴量調整功能及清潔針

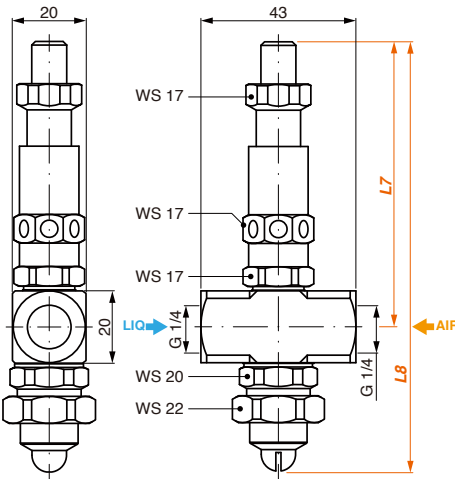

MX自動噴槍本體 / 標準型

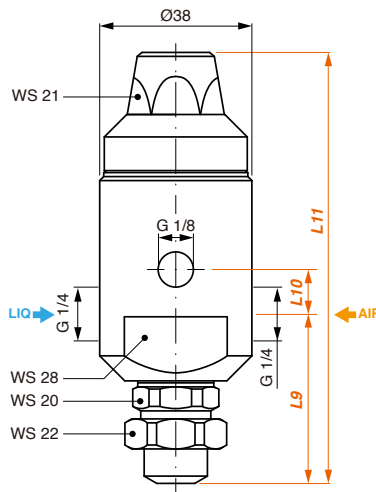

MX自動噴槍本體 / 迷你型

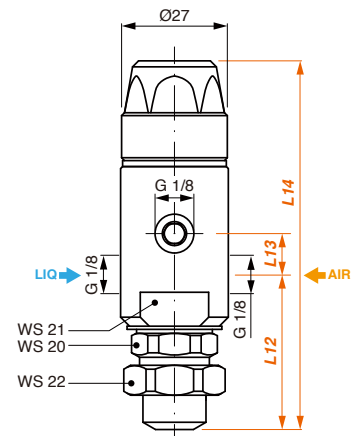

□ MW(1/2"大噴量型)二流體噴嘴尺寸圖

請先選擇噴嘴本體形式及附加功能，再依噴頭形式對照正確噴嘴尺寸(參照右表下方『1/2"大噴量型』尺寸表)

MW大噴量型本體(1/2") / 塞頭(基本型)

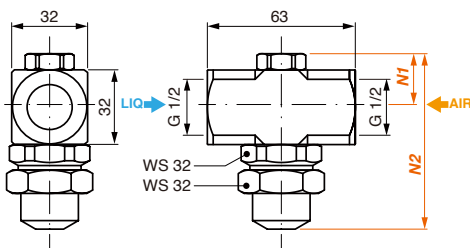

MW大噴量型本體(1/2") / 噴量調整針

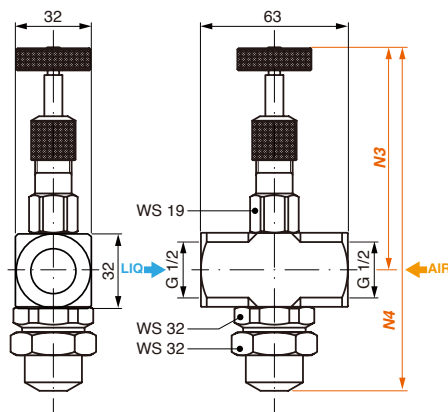

MW大噴量型本體(1/2") / 清潔針

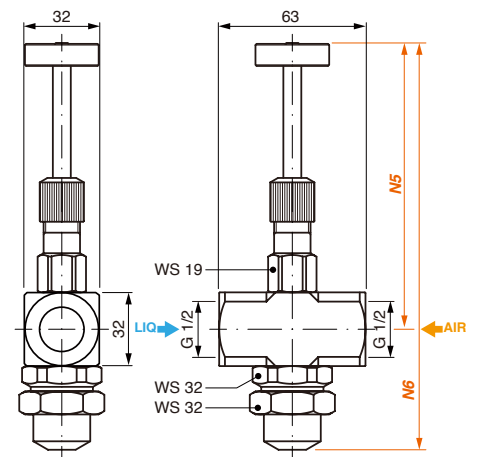

噴頭型號	尺寸代碼														
	L1	L2	L3	L4	L5	L6	L7	L8	L9	L10	L11	L12	L13	L14	
實心圓錐形 <small>(壓力式內混型)</small>	SUB 1520	15.0	51.0	43.0	79.0	63.0	99.0	79.5	115.5	41.0	13.0	108.0	39.0	11.5	93.0
	SUB 1670	15.0	51.0	43.0	79.0	63.0	99.0	79.5	115.5	41.0	13.0	108.0	39.0	11.5	93.0
	SUB 2142	15.0	51.0	43.0	79.0	63.0	99.0	79.5	115.5	41.0	13.0	108.0	39.0	11.5	93.0
	SUC 2376	15.0	51.0	43.0	79.0	63.0	99.0	79.5	115.5	41.0	13.0	108.0	39.0	11.5	93.0
	SUC 2690	15.0	51.0	43.0	79.0	63.0	99.0	79.5	115.5	41.0	13.0	108.0	39.0	11.5	93.0
	SUC 3129	15.0	51.0	43.0	79.0	63.0	99.0	79.5	115.5	41.0	13.0	108.0	39.0	11.5	93.0
廣角實心圓錐形 <small>(壓力式內混型)</small>	SUL 1640	15.0	50.5	43.0	78.5	63.0	98.5	79.5	115.0	40.5	13.0	107.5	38.5	11.5	92.5
	SUM 2220	15.0	52.5	43.0	80.5	63.0	100.5	79.5	117.0	42.5	13.0	109.5	40.5	11.5	94.5
	SUL 2330	15.0	52.5	43.0	80.5	63.0	100.5	79.5	117.0	42.5	13.0	109.5	40.5	11.5	94.5
	SUM 2460	15.0	52.5	43.0	80.5	63.0	100.5	79.5	117.0	42.5	13.0	109.5	40.5	11.5	94.5
	SUM 2860	15.0	52.5	43.0	80.5	63.0	100.5	79.5	117.0	42.5	13.0	109.5	40.5	11.5	94.5
	SUQ 3140	15.0	55.0	43.0	83.0	63.0	103.0	79.5	119.5	45.0	13.0	112.0	43.0	11.5	97.0
扇形 <small>(壓力式內混型)</small>	SUU 2101	15.0	51.7	43.0	79.7	63.0	99.7	79.5	116.2	41.7	13.0	108.7	39.7	11.5	93.7
	SUU 2160	15.0	51.7	43.0	79.7	63.0	99.7	79.5	116.2	41.7	13.0	108.7	39.7	11.5	93.7
	SUM 2167	15.0	51.7	43.0	79.7	63.0	99.7	79.5	116.2	41.7	13.0	108.7	39.7	11.5	93.7
	SUU 2171	15.0	51.7	43.0	79.7	63.0	99.7	79.5	116.2	41.7	13.0	108.7	39.7	11.5	93.7
	SUM 2320	15.0	56.0	43.0	84.0	63.0	104.0	79.5	120.5	46.0	13.0	113.0	44.0	11.5	98.0
	SUM 2600	15.0	56.0	43.0	84.0	63.0	104.0	79.5	120.5	46.0	13.0	113.0	44.0	11.5	98.0
實心圓錐形 <small>(虹吸式內混型)</small>	SUQ 2700	15.0	56.0	43.0	84.0	63.0	104.0	79.5	120.5	46.0	13.0	113.0	44.0	11.5	98.0
	SUQ 3126	15.0	56.0	43.0	84.0	63.0	104.0	79.5	120.5	46.0	13.0	113.0	44.0	11.5	98.0
	SUC 1120	15.0	46.0	43.0	74.0	63.0	94.0	79.5	110.5	36.0	13.0	103.0	34.0	11.5	88.0
	SUC 1190	15.0	46.0	43.0	74.0	63.0	94.0	79.5	110.5	36.0	13.0	103.0	34.0	11.5	88.0
	SUC 1200	15.0	46.0	43.0	74.0	63.0	94.0	79.5	110.5	36.0	13.0	103.0	34.0	11.5	88.0
	SUC 1290	15.0	46.0	43.0	74.0	63.0	94.0	79.5	110.5	36.0	13.0	103.0	34.0	11.5	88.0
扇形 <small>(虹吸式內混型)</small>	SUC 2105	15.0	46.0	43.0	74.0	63.0	94.0	79.5	110.5	36.0	13.0	103.0	34.0	11.5	88.0
	SUC 2180	15.0	46.0	43.0	74.0	63.0	94.0	79.5	110.5	36.0	13.0	103.0	34.0	11.5	88.0
	SUQ 0860	15.0	51.7	43.0	79.7	63.0	99.7	79.5	116.2	41.7	13.0	108.7	39.7	11.5	93.7
	SUQ 1280	15.0	56.0	43.0	84.0	63.0	104.0	79.5	120.5	46.0	13.0	113.0	44.0	11.5	98.0
	SUQ 1370	15.0	56.0	43.0	84.0	63.0	104.0	79.5	120.5	46.0	13.0	113.0	44.0	11.5	98.0
	SUQ 1540	15.0	56.0	43.0	84.0	63.0	104.0	79.5	120.5	46.0	13.0	113.0	44.0	11.5	98.0
扇形 <small>(壓力式外混型)</small>	SUL 2110	15.0	49.0	43.0	77.0	63.0	97.0	79.5	113.5	39.0	13.0	106.0	37.0	11.5	91.0
	SUT 2111	15.0	51.0	43.0	79.0	63.0	99.0	79.5	115.5	41.0	13.0	108.0	39.0	11.5	93.0
	SUR 2166	15.0	49.0	43.0	77.0	63.0	97.0	79.5	113.5	39.0	13.0	106.0	37.0	11.5	91.0
	SUV 2172	15.0	51.0	43.0	79.0	63.0	99.0	79.5	115.5	41.0	13.0	108.0	39.0	11.5	93.0
	SUS 2330	15.0	49.0	43.0	77.0	63.0	97.0	79.5	113.5	39.0	13.0	106.0	37.0	11.5	91.0
	SUV 2331	15.0	51.0	43.0	79.0	63.0	99.0	79.5	115.5	41.0	13.0	108.0	39.0	11.5	93.0
	SUQ 2520	15.0	49.0	43.0	77.0	63.0	97.0	79.5	113.5	39.0	13.0	106.0	37.0	11.5	91.0
	SUV 2521	15.0	51.0	43.0	79.0	63.0	99.0	79.5	115.5	41.0	13.0	108.0	39.0	11.5	93.0
	SUT 2680	15.0	49.0	43.0	77.0	63.0	97.0	79.5	113.5	39.0	13.0	106.0	37.0	11.5	91.0
	SUV 2681	15.0	51.0	43.0	79.0	63.0	99.0	79.5	115.5	41.0	13.0	108.0	39.0	11.5	93.0
	SUN 3101	15.0	49.0	43.0	77.0	63.0	97.0	79.5	113.5	39.0	13.0	106.0	37.0	11.5	91.0
	SUN 3102	15.0	49.0	43.0	77.0	63.0	97.0	79.5	113.5	39.0	13.0	106.0	37.0	11.5	91.0
	SUW 3141	15.0	51.0	43.0	79.0	63.0	99.0	79.5	115.5	41.0	13.0	108.0	39.0	11.5	93.0
	SUN 3175	15.0	49.0	43.0	77.0	63.0	97.0	79.5	113.5	39.0	13.0	106.0	37.0	11.5	91.0
SUN 3280	15.0	49.0	43.0	77.0	63.0	97.0	79.5	113.5	39.0	13.0	106.0	37.0	11.5	91.0	

噴頭型號	尺寸代碼						噴頭型式	
	N1	N2	N3	N4	N5	N6		
1/2" 大噴量型	SUL 3316	23.0	87.3	96.0	160.3	124.0	188.3	廣角實心圓錐形 <small>(壓力式內混型)</small>
	SUL 3192	23.0	87.3	96.0	160.3	124.0	188.3	
	SUL 3300	23.0	87.3	96.0	160.3	124.0	188.3	
	SUM 3740	23.0	87.3	96.0	160.3	124.0	188.3	
	SUB 3230	23.0	76.3	96.0	149.3	124.0	177.3	實心圓錐形 <small>(壓力式內混型)</small>
	SUB 3740	23.0	76.3	96.0	149.3	124.0	177.3	
	SUM 3184	23.0	87.3	96.0	160.3	124.0	188.3	扇形 <small>(壓力式內混型)</small>
	SUQ 3740	23.0	87.3	96.0	160.3	124.0	188.3	
	SUM 4145	23.0	81.3	96.0	154.3	124.0	182.3	扇形 <small>(壓力式外混型)</small>
	SUZ 3460	23.0	81.3	96.0	154.3	124.0	182.3	空心圓錐形 <small>(壓力式內混型)</small>
SUC 2230	23.0	81.3	96.0	154.3	124.0	182.3	實心圓錐形 <small>(虹吸式內混型)</small>	