

虹吸式

內部混合型噴頭 \ 實心圓錐形

本系列實心圓錐形噴頭，屬於虹吸型內混式，液體不需要經由泵浦加壓，直接由噴嘴吸入，對於無法提供液體加壓設備的作業環境，與不適合使用泵浦加壓的液體來說，虹吸型噴頭會是最佳的選擇。液體與壓縮空氣先在噴嘴內部的混合室(Mixing Chamber)均勻混合，再經由噴嘴噴出，內部混合式噴頭的最大優點是霧化液滴微小均勻，適用在低黏度、不易結晶的液體噴霧應用。

典型應用 產品塗佈、產品冷卻、環境加濕、消毒殺菌



噴頭型號	空氣壓力(bar)		空氣流量 (NI/min)								液體流量 (l/hour)				參考噴幅		
	Ln 液體帽型號	An 空氣帽型號	空氣壓力 (bar)								空氣壓力	HR	C	HM			
			0.7	1.5	3.0	4.0	1.5	1.3	1.1	0.9					0.7	0.5	-
SUC 1120	0.7	11	1.5	1.3	1.1	0.9	0.7	0.5	-	-	0.7	280	89	1800			
Ln XMW 5006	1.5	17	1.8	1.7	1.5	1.3	1.2	1.1	0.6	-	1.5	280	89	1900			
An XMW 4040	3.0	28	2.1	1.9	1.7	1.5	1.4	1.3	1.1	0.8	3.0	300	95	2300			
	4.0	36	2.2	2.0	1.8	1.6	1.5	1.4	1.2	0.9	4.0	360	114	2600			
SUC 1190	0.7	13	2.4	2.1	1.7	1.5	1.2	0.8	-	-	0.7	300	95	2100			
Ln XMW 5001	1.5	20	2.8	2.6	2.4	2.1	1.9	1.6	0.9	-	1.5	330	104	2300			
An XMW 4040	3.0	32	3.4	3.1	2.9	2.8	2.6	2.4	1.7	1.1	3.0	380	120	2600			
	4.0	41	3.7	3.4	3.3	3.1	2.9	2.7	2.1	1.5	4.0	430	144	3000			
SUC 1200	0.7	23	2.5	2.3	2.0	1.6	1.4	1.1	-	-	0.7	300	95	2400			
Ln XMW 5001	1.5	36	2.9	2.8	2.5	2.2	2.0	1.7	0.9	-	1.5	330	104	2700			
An XMW 4041	3.0	58	3.4	3.3	3.2	2.9	2.8	2.5	1.9	1.2	3.0	380	127	3400			
	4.0	74	3.7	3.6	3.5	3.4	3.3	3.0	2.5	2.0	4.0	430	151	4000			
SUC 1290	0.7	19	4.5	4.0	3.4	2.1	1.8	1.4	-	-	0.7	380	140	3000			
Ln XMW 5002	1.5	31	5.3	4.9	4.4	3.5	2.9	2.7	1.8	-	1.5	410	152	3400			
An XMW 4041	3.0	50	6.0	5.6	5.0	4.4	4.0	3.4	2.4	1.2	3.0	460	170	4000			
	4.0	65	5.7	5.4	5.0	4.2	3.9	3.5	2.8	1.9	4.0	510	198	4600			
SUC 2105	1.5	58	22.0	19.9	16.3	12.3	10.5	8.3	2.8	-	1.5	460	137	3700			
Ln XMW 5004	3.0	88	25.0	23.0	19.5	16.7	14.2	11.5	6.4	2.8	3.0	510	161	4300			
An XMW 4042	4.0	111	26.0	24.0	21.0	18.4	15.7	12.9	7.9	4.5	4.0	530	168	4900			
	5.6	147	26.0	24.0	22.0	19.7	17.0	14.6	9.8	6.1	5.6	580	194	5500			
SUC 2180	2.0	144	-	-	-	27.0	22.0	16.8	-	-	2.0	510	180	6700			
Ln XMW 5005	3.0	190	-	-	-	30.0	26.0	21.0	-	-	3.0	530	187	7000			
An XMW 4043	4.0	240	-	43.0	40.0	31.0	28.0	23.0	11.0	-	4.0	580	215	7600			
	5.6	315	44.0	42.0	39.0	31.0	28.0	24.0	16.7	8.3	5.6	630	245	8200			

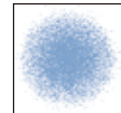
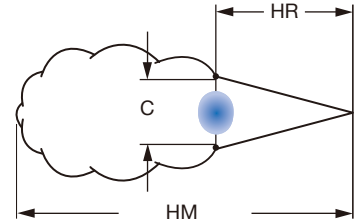

噴霧斷面

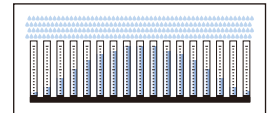

流量分布：標準凸形分布

450	300	150	100	200	300	600	900
Gravity head (mm)			Suction head (mm)				

虹吸式

內部混合型噴頭 \ 扇形

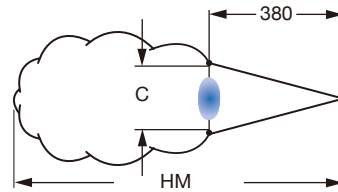

噴頭型號	空氣壓力(bar)		空氣流量 (NI/min)								參考噴幅		
	Ln 液體帽型號	An 空氣帽型號	空氣壓力 (bar)								空氣壓力	C	HM
			0.7	1.5	2.0	1.5	1.2	1.1	1.0	0.8			
SUQ 0860	0.7	28	1.3	1.2	1.1	1.0	1.0	0.8	0.6	0.5	0.7	380	2100
Ln XMW 5002	1.5	43	1.2	1.1	1.0	0.9	0.9	0.8	0.7	0.5	1.5	380	2100
An XMW 4026	2.0	50	0.8	0.8	0.7	0.6	0.5	-	-	-	2.0	380	1800
SUQ 1280	1.5	56	3.7	3.5	3.3	2.9	2.8	2.5	2.3	2.1	1.5	380	2700
Ln XMW 5007	2.0	65	3.4	3.3	3.1	2.8	2.7	2.6	2.4	2.2	2.0	420	2700
An XMW 4027	3.0	87	2.8	2.7	2.5	2.4	2.2	2.1	1.9	1.7	3.0	460	3000
	4.0	110	1.9	1.8	1.6	1.5	1.3	1.2	-	-	4.0	480	2700
SUQ 1370	1.5	68	5.1	4.8	4.5	3.8	3.7	3.5	3.0	2.4	1.5	270	3400
Ln XMW 5003	2.0	78	4.9	4.7	4.4	3.6	3.4	3.2	2.9	2.3	2.0	280	3400
An XMW 4028	3.0	103	3.4	3.2	3.0	2.2	2.0	1.7	-	-	3.0	300	3000
	3.5	117	2.2	2.0	1.7	-	-	-	-	-	-	-	-
SUQ 1540	1.5	63	7.6	7.2	6.6	5.7	5.4	5.1	4.6	3.7	1.5	270	3400
Ln XMW 5003	2.0	73	7.6	7.3	6.8	5.9	5.7	5.5	5.0	4.2	2.0	290	3400
An XMW 4029	3.0	96	6.4	6.1	5.7	5.0	4.5	4.1	3.3	-	3.0	330	3400
	3.5	110	4.2	3.7	3.2	2.6	-	-	-	-	-	-	-

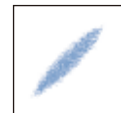

噴霧斷面

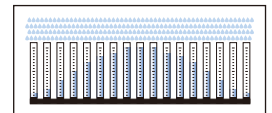













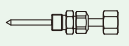

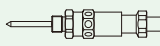
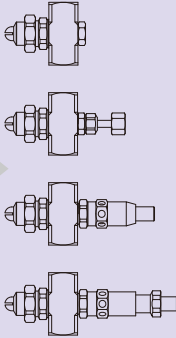
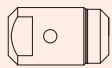

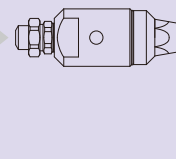

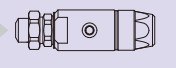
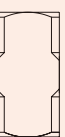

流量分布：標準凸形分布

450	300	150	100	200	300	600	900
Gravity head (mm)			Suction head (mm)				

請參照下表，依噴嘴功能及需求條件組合完整的二流體噴嘴型號

編碼方式說明

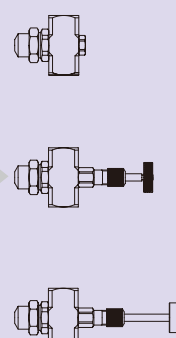
1. 選擇搭配本體形式	2. 選擇適合的噴頭形式 螺帽 空氣噴嘴 液體噴嘴 密封墊圈	3. 選擇噴嘴材質	4. 選擇噴嘴附加功能 MW系列功能代碼一碼 MX系列功能代碼二碼	5. 選擇噴嘴接頭形式	完成二流體噴嘴
1/4" MW 標準本體 	標準實心圓錐形 P.12 壓力式 內部混合型  廣角實心圓錐形 P.13 壓力式 內部混合型  扇形 P.14 壓力式 內部混合型 	B1 / SUS303 B3 / SUS316 D1 / PVC E6 / LUCITE T8 / 黃銅鍍鍍	A / 塞頭(基本型)  B / 噴量調整針  C / 清潔針  D / 清潔針及噴量調整功能 	B / BSP Female (EU) N / NPT Female (US)	
1/4" MX 自動噴槍本體 標準型 	實心圓錐形 P.15 虹吸式 內部混合型  扇形 P.15 虹吸式 內部混合型 	B1 / SUS303 B3 / SUS316 T8 / 黃銅鍍鍍	S / 標準型 U / 標準型 單一氣源入口 A / 逆止功能 B / 清潔針及逆止功能	B / BSP Female (EU) N / NPT Female (US)	
1/8" MX 自動噴槍本體 迷你型 	扇形 P.16 壓力式 外部混合型 	T8 / 黃銅鍍鍍	M / 迷你型 N / 迷你型 單一氣源入口	N / NPT Female (US)	
1/2" MW 大噴量型本體 	廣角實心圓錐形 P.19 壓力式 內混型  實心圓錐形 P.19 壓力式 內混型  扇形 P.19 壓力式 內混型  扇形 P.20 壓力式 外混型  空心圓錐形 P.20 壓力式 內混型  實心圓錐形 P.20 虹吸式 內混型 	B1 / SUS303 B3 / SUS316 D1 / PVC T8 / 黃銅鍍鍍	A / 塞頭(基本型)  B / 噴量調整針  C / 清潔針 	B / BSP Female (EU) N / NPT Female (US)	

洽詢方式說明

範例 MXB 1520 B1SAB

1. 本體形式
MX
 請參閱上表步驟1

2. 二流體噴頭組
B 1520
 請參閱上表步驟2
SUB 1520 → B 1520
 ① 選定《二流體噴頭組》型號SUB 1520
 ② 將SU(Set Up) 移除，使用型號為B 1520。

3. 材質
B1
 請參閱上表步驟3

4. 附加功能
SA
 請參閱上表步驟4
 MW系列功能代碼一碼
 MX系列功能代碼二碼

5. 接頭形式
B
 請參閱上表步驟5

噴嘴零件功能說明 / 依噴嘴功能及需求條件組合完整的二流體噴嘴型號

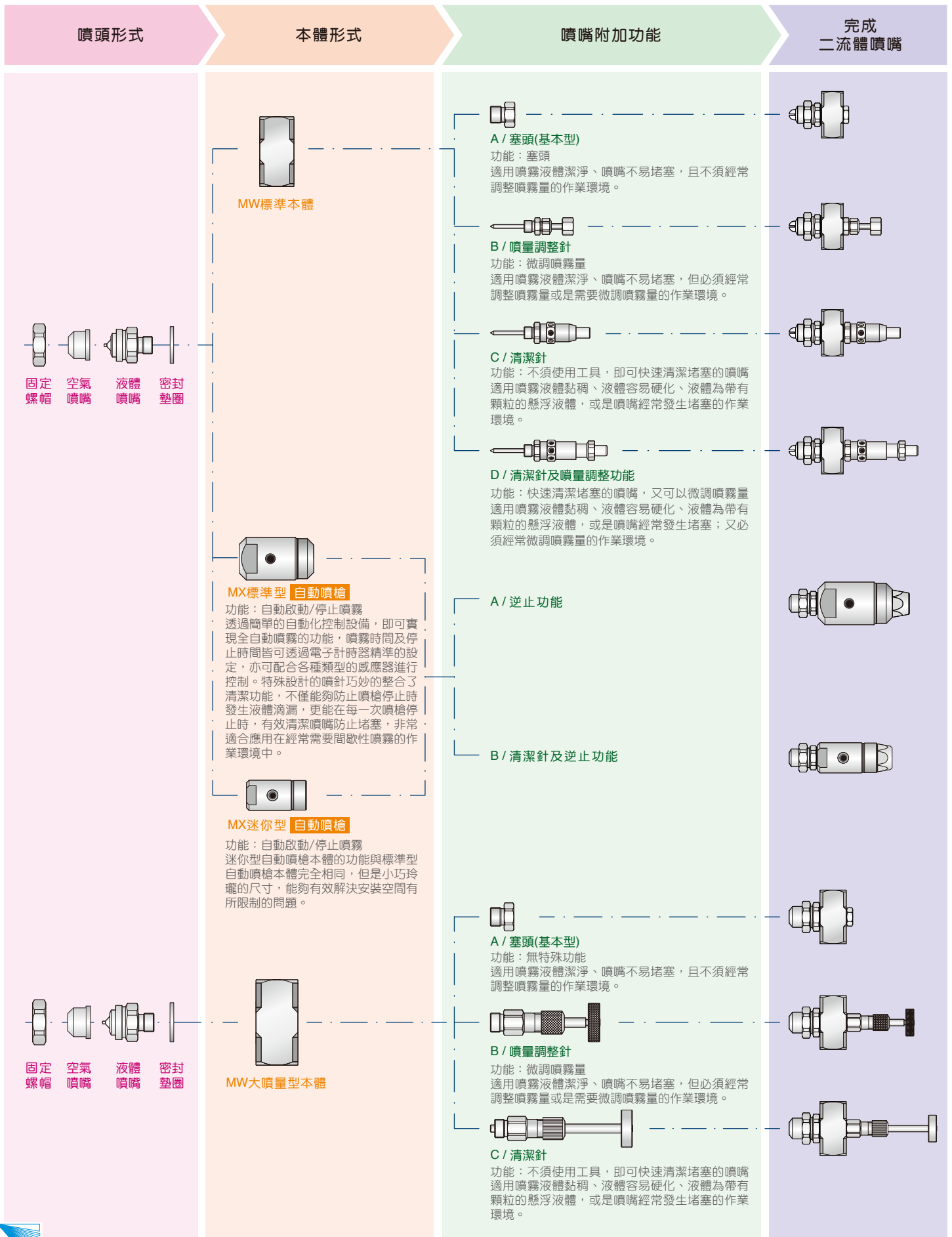

MW二流體噴嘴及MX自動噴槍尺寸圖

MW(1/4"標準型)二流體噴嘴 & MX自動噴槍尺寸圖

請先選擇噴嘴本體形式及附加功能，再依噴頭形式對照正確噴嘴尺寸(參照右表尺寸表)

MW標準本體 / 塞頭(基本型)

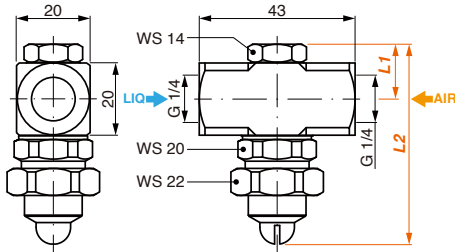

MW標準本體 / 噴量調整針

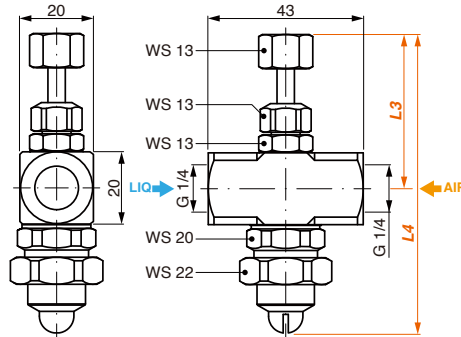

MW標準本體 / 清潔針

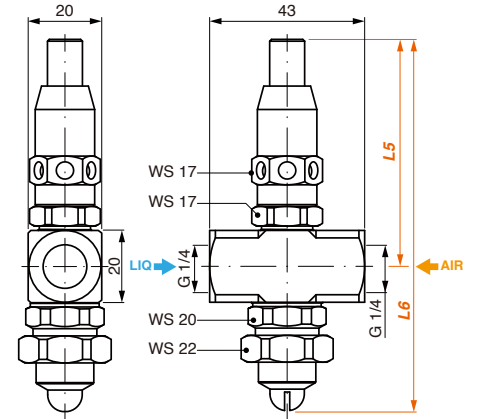

MW標準本體 / 噴量調整功能及清潔針

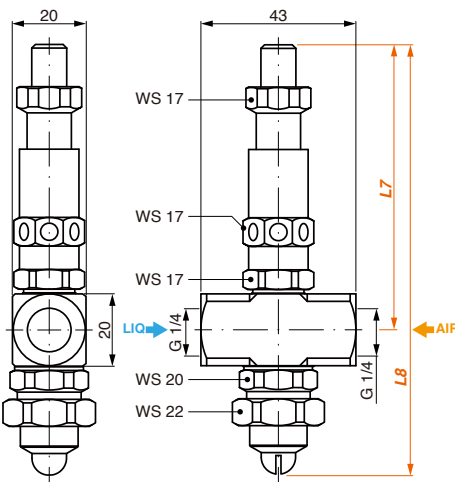

MX自動噴槍本體 / 標準型

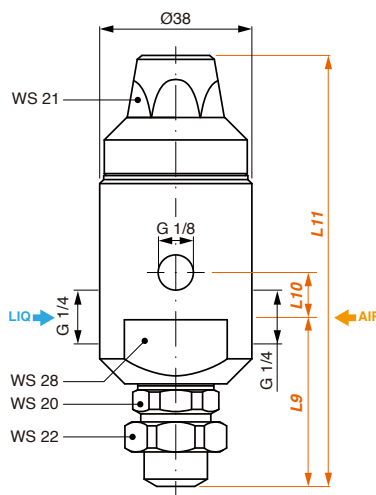

MX自動噴槍本體 / 迷你型

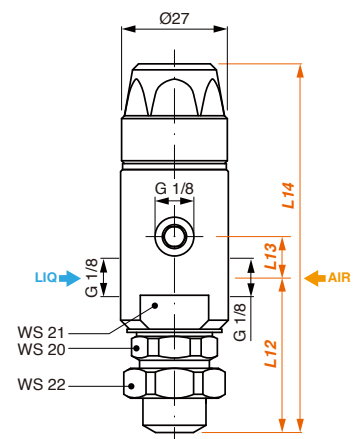

MW(1/2"大噴量型)二流體噴嘴尺寸圖

請先選擇噴嘴本體形式及附加功能，再依噴頭形式對照正確噴嘴尺寸(參照右表下方『1/2"大噴量型』尺寸表)

MW大噴量型本體(1/2") / 塞頭(基本型)

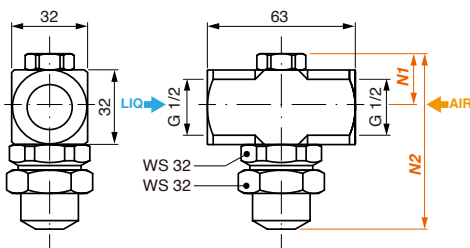

MW大噴量型本體(1/2") / 噴量調整針

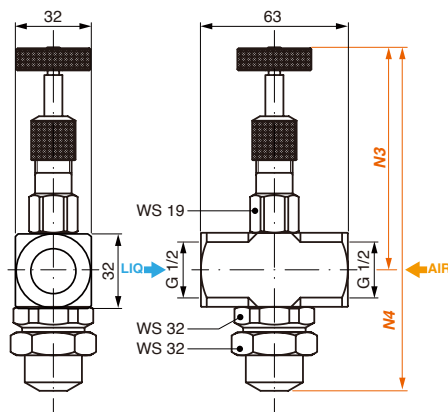

MW大噴量型本體(1/2") / 清潔針

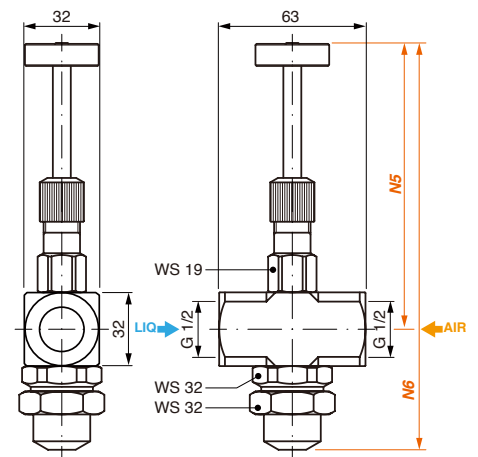

噴頭型號	尺寸代碼														
	L1	L2	L3	L4	L5	L6	L7	L8	L9	L10	L11	L12	L13	L14	
實心圓錐形 <small>(壓力式內混型)</small>	SUB 1520	15.0	51.0	43.0	79.0	63.0	99.0	79.5	115.5	41.0	13.0	108.0	39.0	11.5	93.0
	SUB 1670	15.0	51.0	43.0	79.0	63.0	99.0	79.5	115.5	41.0	13.0	108.0	39.0	11.5	93.0
	SUB 2142	15.0	51.0	43.0	79.0	63.0	99.0	79.5	115.5	41.0	13.0	108.0	39.0	11.5	93.0
	SUC 2376	15.0	51.0	43.0	79.0	63.0	99.0	79.5	115.5	41.0	13.0	108.0	39.0	11.5	93.0
	SUC 2690	15.0	51.0	43.0	79.0	63.0	99.0	79.5	115.5	41.0	13.0	108.0	39.0	11.5	93.0
	SUC 3129	15.0	51.0	43.0	79.0	63.0	99.0	79.5	115.5	41.0	13.0	108.0	39.0	11.5	93.0
廣角實心圓錐形 <small>(壓力式內混型)</small>	SUL 1640	15.0	50.5	43.0	78.5	63.0	98.5	79.5	115.0	40.5	13.0	107.5	38.5	11.5	92.5
	SUM 2220	15.0	52.5	43.0	80.5	63.0	100.5	79.5	117.0	42.5	13.0	109.5	40.5	11.5	94.5
	SUL 2330	15.0	52.5	43.0	80.5	63.0	100.5	79.5	117.0	42.5	13.0	109.5	40.5	11.5	94.5
	SUM 2460	15.0	52.5	43.0	80.5	63.0	100.5	79.5	117.0	42.5	13.0	109.5	40.5	11.5	94.5
	SUM 2860	15.0	52.5	43.0	80.5	63.0	100.5	79.5	117.0	42.5	13.0	109.5	40.5	11.5	94.5
	SUQ 3140	15.0	55.0	43.0	83.0	63.0	103.0	79.5	119.5	45.0	13.0	112.0	43.0	11.5	97.0
扇形 <small>(壓力式內混型)</small>	SUU 2101	15.0	51.7	43.0	79.7	63.0	99.7	79.5	116.2	41.7	13.0	108.7	39.7	11.5	93.7
	SUU 2160	15.0	51.7	43.0	79.7	63.0	99.7	79.5	116.2	41.7	13.0	108.7	39.7	11.5	93.7
	SUM 2167	15.0	51.7	43.0	79.7	63.0	99.7	79.5	116.2	41.7	13.0	108.7	39.7	11.5	93.7
	SUU 2171	15.0	51.7	43.0	79.7	63.0	99.7	79.5	116.2	41.7	13.0	108.7	39.7	11.5	93.7
	SUM 2320	15.0	56.0	43.0	84.0	63.0	104.0	79.5	120.5	46.0	13.0	113.0	44.0	11.5	98.0
	SUM 2600	15.0	56.0	43.0	84.0	63.0	104.0	79.5	120.5	46.0	13.0	113.0	44.0	11.5	98.0
實心圓錐形 <small>(虹吸式內混型)</small>	SUQ 2700	15.0	56.0	43.0	84.0	63.0	104.0	79.5	120.5	46.0	13.0	113.0	44.0	11.5	98.0
	SUQ 3126	15.0	56.0	43.0	84.0	63.0	104.0	79.5	120.5	46.0	13.0	113.0	44.0	11.5	98.0
	SUC 1120	15.0	46.0	43.0	74.0	63.0	94.0	79.5	110.5	36.0	13.0	103.0	34.0	11.5	88.0
	SUC 1190	15.0	46.0	43.0	74.0	63.0	94.0	79.5	110.5	36.0	13.0	103.0	34.0	11.5	88.0
	SUC 1200	15.0	46.0	43.0	74.0	63.0	94.0	79.5	110.5	36.0	13.0	103.0	34.0	11.5	88.0
	SUC 1290	15.0	46.0	43.0	74.0	63.0	94.0	79.5	110.5	36.0	13.0	103.0	34.0	11.5	88.0
扇形 <small>(虹吸式內混型)</small>	SUC 2105	15.0	46.0	43.0	74.0	63.0	94.0	79.5	110.5	36.0	13.0	103.0	34.0	11.5	88.0
	SUC 2180	15.0	46.0	43.0	74.0	63.0	94.0	79.5	110.5	36.0	13.0	103.0	34.0	11.5	88.0
	SUQ 0860	15.0	51.7	43.0	79.7	63.0	99.7	79.5	116.2	41.7	13.0	108.7	39.7	11.5	93.7
	SUQ 1280	15.0	56.0	43.0	84.0	63.0	104.0	79.5	120.5	46.0	13.0	113.0	44.0	11.5	98.0
	SUQ 1370	15.0	56.0	43.0	84.0	63.0	104.0	79.5	120.5	46.0	13.0	113.0	44.0	11.5	98.0
	SUQ 1540	15.0	56.0	43.0	84.0	63.0	104.0	79.5	120.5	46.0	13.0	113.0	44.0	11.5	98.0
扇形 <small>(壓力式外混型)</small>	SUL 2110	15.0	49.0	43.0	77.0	63.0	97.0	79.5	113.5	39.0	13.0	106.0	37.0	11.5	91.0
	SUT 2111	15.0	51.0	43.0	79.0	63.0	99.0	79.5	115.5	41.0	13.0	108.0	39.0	11.5	93.0
	SUR 2166	15.0	49.0	43.0	77.0	63.0	97.0	79.5	113.5	39.0	13.0	106.0	37.0	11.5	91.0
	SUV 2172	15.0	51.0	43.0	79.0	63.0	99.0	79.5	115.5	41.0	13.0	108.0	39.0	11.5	93.0
	SUS 2330	15.0	49.0	43.0	77.0	63.0	97.0	79.5	113.5	39.0	13.0	106.0	37.0	11.5	91.0
	SUV 2331	15.0	51.0	43.0	79.0	63.0	99.0	79.5	115.5	41.0	13.0	108.0	39.0	11.5	93.0
	SUQ 2520	15.0	49.0	43.0	77.0	63.0	97.0	79.5	113.5	39.0	13.0	106.0	37.0	11.5	91.0
	SUV 2521	15.0	51.0	43.0	79.0	63.0	99.0	79.5	115.5	41.0	13.0	108.0	39.0	11.5	93.0
	SUT 2680	15.0	49.0	43.0	77.0	63.0	97.0	79.5	113.5	39.0	13.0	106.0	37.0	11.5	91.0
	SUV 2681	15.0	51.0	43.0	79.0	63.0	99.0	79.5	115.5	41.0	13.0	108.0	39.0	11.5	93.0
	SUN 3101	15.0	49.0	43.0	77.0	63.0	97.0	79.5	113.5	39.0	13.0	106.0	37.0	11.5	91.0
	SUN 3102	15.0	49.0	43.0	77.0	63.0	97.0	79.5	113.5	39.0	13.0	106.0	37.0	11.5	91.0
	SUW 3141	15.0	51.0	43.0	79.0	63.0	99.0	79.5	115.5	41.0	13.0	108.0	39.0	11.5	93.0
	SUN 3175	15.0	49.0	43.0	77.0	63.0	97.0	79.5	113.5	39.0	13.0	106.0	37.0	11.5	91.0
SUN 3280	15.0	49.0	43.0	77.0	63.0	97.0	79.5	113.5	39.0	13.0	106.0	37.0	11.5	91.0	

噴頭型號	尺寸代碼						噴頭型式	
	N1	N2	N3	N4	N5	N6		
1/2" 大噴量型	SUL 3316	23.0	87.3	96.0	160.3	124.0	188.3	廣角實心圓錐形 <small>(壓力式內混型)</small>
	SUL 3192	23.0	87.3	96.0	160.3	124.0	188.3	
	SUL 3300	23.0	87.3	96.0	160.3	124.0	188.3	
	SUM 3740	23.0	87.3	96.0	160.3	124.0	188.3	
	SUB 3230	23.0	76.3	96.0	149.3	124.0	177.3	實心圓錐形 <small>(壓力式內混型)</small>
	SUB 3740	23.0	76.3	96.0	149.3	124.0	177.3	
SUM 3184	23.0	87.3	96.0	160.3	124.0	188.3	扇形 <small>(壓力式內混型)</small>	
SUQ 3740	23.0	87.3	96.0	160.3	124.0	188.3		
SUM 4145	23.0	81.3	96.0	154.3	124.0	182.3	扇形 <small>(壓力式外混型)</small>	
SUZ 3460	23.0	81.3	96.0	154.3	124.0	182.3	空心圓錐形 <small>(壓力式內混型)</small>	
SUC 2230	23.0	81.3	96.0	154.3	124.0	182.3	實心圓錐形 <small>(虹吸式內混型)</small>	