

扇形 / 外部混合型噴頭

壓力式



本系列扇形噴嘴，屬於壓力型外混式，液體必須經由加壓後輸送至噴嘴，外混式噴嘴與內混式噴嘴，結構上大不相同，不僅噴嘴內部沒有混合室(Mixing Chamber)，液體與壓縮空氣具有各自獨立的管路系統，而且液體與壓縮空氣的霧化過程是在噴嘴外部進行的，因此，對於黏度較高、易結晶、及含有固態物質的懸浮液體來說，外部混合式的噴嘴，絕對是最佳的選擇。

典型應用 助焊劑噴塗、潤滑劑噴塗、防銹劑噴塗

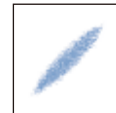
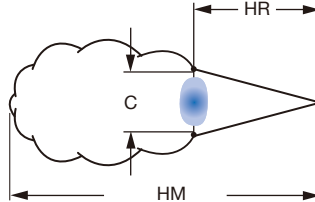

噴霧斷面

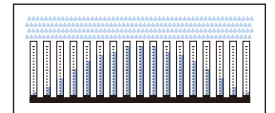

流量分布：標準凸形分布

噴頭型號	空氣壓力(bar)												參考數據				
	0.2		0.3		0.7		1.5		3.0		噴霧量 l/hour	氣體 消耗量 NI/min	空氣 壓力	液體 壓力	參考噴幅		
	噴霧量 l/hour	氣體 消耗量 NI/min	噴霧量 l/hour	氣體 消耗量 NI/min	噴霧量 l/hour	氣體 消耗量 NI/min	噴霧量 l/hour	氣體 消耗量 NI/min	噴霧量 l/hour	氣體 消耗量 NI/min					C	HM	HR
SUL 2110	0.2	25	0.4	26	0.7	31	1.4	45	2.8	74	11	0.2	0.2	230	900	150	
	0.4	26	0.7	31	1.1	40	1.8	54	3.5	85	11	1.1	0.2	230	1200	150	
	0.7	31	1.1	40	1.4	45	2.1	60	4.2	102	11	1.4	0.4	230	1200	150	
	1.1	40	1.4	45	1.8	54	2.8	74	4.9	119	11	1.4	1.4	250	1500	180	
	1.4	45	1.8	54	2.1	59	3.5	85	5.3	128	11	1.8	0.7	240	1500	150	
	1.8	54	2.1	59	2.8	74	4.2	102	5.6	139	11	2.8	1.4	280	1800	180	
	2.1	59	2.8	74	3.5	85	5.6	139	6.3	159	11	4.9	2.8	240	2400	180	
Ln XMW 5006																	
An XMW 4030																	
SUT 2111	0.4	22	0.4	22	0.4	25	0.6	28	0.7	34	11	0.6	0.7	400	1800	300	
	0.5	25	0.5	25	0.6	28	0.7	34	1.1	45	11	0.6	1.5	460	1800	350	
	0.5	27	0.6	28	0.7	34	1.1	45	1.8	62	11	1.4	1.5	410	2700	300	
	0.6	28	0.7	34	0.9	40	1.4	54	2.5	79	11	1.1	2.0	480	2600	350	
Ln XMW 5006																	
An XMW 4031																	
SUR 2166	0.4	26	0.7	31	1.1	40	1.8	54	3.2	82	16.6	0.4	0.2	220	1000	140	
	0.7	31	1.1	40	1.4	45	2.1	59	3.5	85	16.6	1.4	0.2	220	1700	150	
	1.1	40	1.4	45	1.8	54	2.8	74	4.2	102	16.6	1.8	0.4	230	1800	165	
	1.4	45	1.8	54	2.1	59	3.5	85	4.9	119	16.6	1.8	1.4	290	2100	190	
	1.8	54	2.1	59	2.8	74	4.2	102	5.3	127	16.6	2.1	0.7	250	1800	180	
	2.1	59	2.8	74	3.5	85	4.9	119	6.3	159	16.6	3.5	1.4	300	2400	220	
	2.8	74	3.5	85	4.2	102	6.3	159	6.7	164	16.6	5.3	2.8	250	3000	190	
Ln XMW 5001																	
An XMW 4030																	
SUV 2172	0.4	22	0.4	22	0.6	28	0.7	34	1.1	45	17.2	0.7	1.5	580	1800	460	
	0.6	28	0.7	34	0.7	34	1.4	54	1.4	54	17.2	1.4	1.5	560	2400	430	
	0.7	34	1.1	45	1.4	54	2.1	71	2.1	71	17.2	1.8	2.0	580	2700	460	
	1.1	45	1.4	54	2.1	71	2.5	79	2.5	79	17.2	1.8	3.0	660	2900	480	
Ln XMW 5001																	
An XMW 4031																	
SUS 2330	0.7	31	1.1	40	1.4	45	2.5	68	3.5	85	33	0.7	0.2	250	1200	165	
	1.1	40	1.4	45	1.8	54	2.8	74	4.2	102	33	1.8	0.2	250	1800	165	
	1.4	45	1.8	54	2.1	59	3.5	85	4.9	119	33	2.1	0.4	240	1800	180	
	1.8	54	2.1	59	2.8	74	4.2	102	5.3	127	33	2.5	1.4	320	1800	200	
	2.1	59	2.8	74	3.5	85	4.9	119	5.6	139	33	2.8	0.7	300	2300	190	
	2.8	74	3.5	85	4.2	102	5.6	139	6.3	159	33	4.2	1.4	360	3000	200	
	3.5	85	4.2	102	4.9	119	6.3	159	7.0	176	33	5.3	2.8	300	4000	200	
Ln XMW 5002																	
An XMW 4030																	
SUV 2331	0.4	25	0.4	25	0.4	25	0.7	34	1.4	54	33	0.6	0.7	630	1500	480	
	0.5	27	0.6	28	0.6	28	0.9	40	1.8	62	33	0.7	1.5	630	1800	480	
	0.6	28	0.7	31	0.7	34	1.1	45	2.1	71	33	1.4	1.5	660	2400	530	
	0.7	34	0.8	34	0.9	40	1.4	54	2.5	79	33	1.8	2.0	690	2700	510	
Ln XMW 5002																	
An XMW 4031																	
SUQ 2520	0.7	85	1.0	102	1.4	116	2.5	178	3.2	212	52	0.7	0.2	250	1700	190	
	1.0	102	1.4	116	1.8	139	2.8	195	3.5	232	52	1.8	0.2	250	2700	190	
	1.4	116	1.8	139	2.1	156	3.5	227	3.9	255	52	2.1	0.4	280	3000	190	
	1.8	139	2.1	156	2.5	178	4.2	266	4.2	275	52	2.5	0.7	280	3500	220	
	2.1	156	2.8	195	2.8	195	4.9	312	4.9	314	52	2.5	1.4	360	3700	230	
	2.8	195	3.5	227	3.5	227	5.6	360	5.6	360	52	4.2	1.4	370	4300	230	
	3.5	227	4.2	266	4.2	266	6.3	411	6.3	411	52	4.9	2.8	320	4900	220	
Ln XMW 5007																	
An XMW 4032																	
SUV 2521	0.6	91	0.7	102	1.4	156	2.1	210	3.2	285	52	2.1	0.7	560	4300	400	
	0.7	102	1.1	130	2.1	210	2.8	260	4.2	360	52	2.1	1.5	580	4000	460	
	1.1	130	1.8	184	2.5	235	3.5	310	5.3	430	52	4.2	1.5	640	5200	480	
	1.4	156	2.1	210	2.8	260	4.2	360	5.6	455	52	3.9	2.0	690	4600	510	
Ln XMW 5007																	
An XMW 4033																	



洽詢方式說明 範例 MWL 2110 B1BB

<p>1. 本體形式</p> <p>MW</p> <p>請參閱P10說明</p>	<p>2. 二流體噴頭組</p> <p>L 2110</p> <p>請參閱上表</p>	<p>SUL 2110 → L 2110</p> <p>選定噴頭型號SUL 2110 請將SU(Set Up) 移除 使用型號為L 2110。</p>	<p>3. 材質</p> <p>B1</p> <p>請參閱P10說明</p>	<p>4. 附加功能</p> <p>B</p> <p>請參閱P10說明</p>	<p>5. 接頭形式</p> <p>B</p> <p>請參閱P10說明</p>
--	---	--	--	---	---

壓力式

外部混合型噴頭 \ 扇形

噴頭型號	空氣壓力(bar)										參考數據									
	噴霧量		氣體		噴霧量		氣體		噴霧量		氣體		空氣壓力	液體壓力	參考噴幅					
	l/hour	NI/min	l/hour	NI/min	l/hour	NI/min	l/hour	NI/min	l/hour	NI/min	l/hour	NI/min			C	HM	HR			
SUT 2680	0.7		85	1.4		116	1.8		139	2.8		195	3.5		232	0.7	0.4	270	2100	190
	1.0		102	1.8		139	2.1		156	3.2		212	4.2		275	1.8	0.7	270	3000	190
	1.4		116	2.1		156	2.5		178	3.5		227	4.9		314	2.5	1.4	330	3400	220
	1.8	17.6	139	2.5	22	178	2.8	33	195	4.2	48	266	5.3	68	340	2.8	1.4	360	3800	220
	2.1		156	2.8		195	3.5		227	4.9		312	5.6		360	2.8	1.4	370	4000	250
	2.8		195	3.5		227	4.2		266	5.6		360	6.3		411	4.2	2.1	370	4900	250
Ln XMW 5003 An XMW 4032	3.5		227	4.2		266	4.9		312	6.3		411	6.6		428	5.3	2.8	360	5800	230
SUV 2681	0.6		91	0.7		102	1.1		130	2.5		235	3.5		310	1.8	0.7	640	3000	480
	1.1	17.6	130	1.4	22	156	1.8	33	184	3.2	48	285	4.6	68	380	2.5	1.5	640	3800	460
	1.4		156	1.8		184	2.5		235	3.9		330	6.0		475	4.2	1.5	580	4900	430
Ln XMW 5003 An XMW 4033	1.8		184	2.1		210	2.8		260	4.2		360	6.7		525	4.2	2.0	610	5200	430
SUN 3101	1.0		102	1.8		139	2.5		178	3.2		212	3.9		255	1.0	0.2	250	2700	200
	1.4		116	2.1		156	2.8		195	3.5		227	4.2		275	2.1	0.2	290	3000	220
	1.8		139	2.5		178	3.2		212	3.9		246	4.6		297	2.8	0.4	360	3500	240
	2.1	36	156	2.8	45	195	3.5	68	227	4.2	100	266	4.9	141	314	3.2	1.4	390	3700	280
	2.5		178	3.2		212	4.2		266	4.9		312	5.6		360	3.5	0.7	380	4000	270
	2.8		195	3.5		227	4.9		312	5.6		360	6.3		411	4.2	1.4	390	4800	280
Ln XMW 5004 An XMW 4032	3.5		227	4.2		266	5.6		360	6.3		411	7.0		453	5.6	2.8	380	5900	240
SUN 3102	1.8		235	1.8		235	2.5		300	3.9		410				1.8	0.2	290	3000	200
	2.1		260	2.1		260	2.8		330	4.2		445				2.8	0.2	300	3400	200
	2.5		300	2.5		300	3.2		355	4.6		480				2.8	0.3	300	4000	200
	2.8	36	330	2.8	45	330	3.5	68	380	4.9	100	529				3.5	0.7	320	4300	220
	3.2		355	3.2		355	3.9		410	5.3		565				3.9	1.5	340	4600	220
	3.5		380	3.5		380	4.2		445	5.6		600				4.2	1.0	330	4700	230
Ln XMW 5008 An XMW 4034	4.2		445	4.2		445	4.9		520	6.3		685				4.9	1.5	340	5500	230
SUW 3141	0.7		102	1.1		130	1.8		184	3.2		285	5.3		430	2.8	0.7	810	4000	580
	1.1	36	130	1.4	45	156	2.1	68	210	3.5	100	310	6.0	141	475	3.2	1.5	790	4300	580
	1.4		156	2.1		210	2.8		260	4.9		405	6.7		525	5.6	1.5	660	5800	510
Ln XMW 5004 An XMW 4033	1.8		184	2.5		235	3.2		285	5.9		455	7.0		550	3.9	2.0	840	4300	640
SUN 3175	2.1		260	2.8		330	3.9		410	4.9		520				2.1	0.2	340	3500	240
	2.5		300	3.2		355	4.2		445	5.3		565				3.2	0.2	360	4300	240
	2.8		330	3.5		380	4.6		480	5.6		600				3.9	0.3	360	4900	250
	3.2	64	355	3.9	78	410	4.9	119	520	6.0	175	640				4.9	0.7	360	5500	250
	3.5		380	4.2		445	5.3		565	6.3		685				4.9	1.5	380	5500	250
	4.2		445	4.9		520	5.6		600							5.3	1.0	380	5800	250
Ln XMW 5009 An XMW 4034	4.9		520	5.6		600	6.3		685							5.6	1.5	380	6100	250
SUN 3280	2.8		330	3.5		380	4.6		480	5.6		600				2.8	0.2	360	4600	250
	3.2		355	3.9		410	4.9		520	6.0		640				3.9	0.2	370	4900	250
	3.5		380	4.2		445	5.3		565	6.3		685				4.6	0.3	370	5200	250
	3.9	102	410	4.6	125	480	5.6	192	600		280					5.3	0.7	380	5500	270
	4.2		445	4.9		520	6.0		640							5.6	1.0	410	5500	270
	4.6		480	5.3		565	6.3		685							5.6	1.5	410	5800	270
Ln XMW 5005 An XMW 4034	4.9		520	5.6		600			685							6.0	1.5	410	6100	270















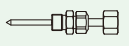

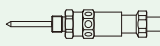
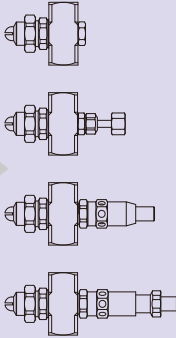
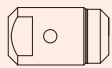

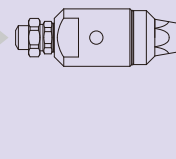

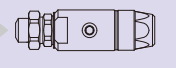
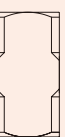

洽詢方式說明 範例 MWT 2680 B1BB

1. 本體形式 MW 請參閱P10說明	2. 二流體噴頭組 T 2680 請參閱上表	SUT 2680 → T 2680 選定噴頭型號SUT 2680 請將SU(Set Up) 移除 使用型號為T 2680。	3. 材質 B1 請參閱P10說明	4. 附加功能 B 請參閱P10說明	5. 接頭形式 B 請參閱P10說明
---	--	---	---------------------------------------	--	--

請參照下表，依噴嘴功能及需求條件組合完整的二流體噴嘴型號

編碼方式說明

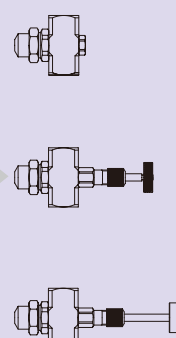
1. 選擇搭配本體形式	2. 選擇適合的噴頭形式 螺帽 空氣噴嘴 液體噴嘴 密封墊圈	3. 選擇噴嘴材質	4. 選擇噴嘴附加功能 MW系列功能代碼一碼 MX系列功能代碼二碼	5. 選擇噴嘴接頭形式	完成二流體噴嘴
1/4" MW 標準本體 	標準實心圓錐形 P.12 壓力式 內部混合型  廣角實心圓錐形 P.13 壓力式 內部混合型  扇形 P.14 壓力式 內部混合型 	B1 / SUS303 B3 / SUS316 D1 / PVC E6 / LUCITE T8 / 黃銅鍍鎳	A / 塞頭(基本型)  B / 噴量調整針  C / 清潔針  D / 清潔針及噴量調整功能 	B / BSP Female (EU) N / NPT Female (US)	
1/4" MX 自動噴槍本體 標準型 	實心圓錐形 P.15 虹吸式 內部混合型  扇形 P.15 虹吸式 內部混合型 	B1 / SUS303 B3 / SUS316 T8 / 黃銅鍍鎳	S / 標準型 U / 標準型 單一氣源入口 A / 逆止功能 B / 清潔針及逆止功能	B / BSP Female (EU) N / NPT Female (US)	
1/8" MX 自動噴槍本體 迷你型 	扇形 P.16 壓力式 外部混合型 	T8 / 黃銅鍍鎳	M / 迷你型 N / 迷你型 單一氣源入口	N / NPT Female (US)	
1/2" MW 大噴量型本體 	廣角實心圓錐形 P.19 壓力式 內混型  實心圓錐形 P.19 壓力式 內混型  扇形 P.19 壓力式 內混型  扇形 P.20 壓力式 外混型  空心圓錐形 P.20 壓力式 內混型  實心圓錐形 P.20 虹吸式 內混型 	B1 / SUS303 B3 / SUS316 D1 / PVC T8 / 黃銅鍍鎳	A / 塞頭(基本型)  B / 噴量調整針  C / 清潔針 	B / BSP Female (EU) N / NPT Female (US)	

洽詢方式說明

範例 MXB 1520 B1SAB

1. 本體形式
MX
 請參閱上表步驟1

2. 二流體噴頭組
B 1520
 請參閱上表步驟2
SUB 1520 → B 1520

① 選定《二流體噴頭組》型號SUB 1520
 ② 將SU(Set Up) 移除，使用型號為B 1520。

3. 材質
B1
 請參閱上表步驟3

4. 附加功能
SA
 請參閱上表步驟4
 MW系列功能代碼一碼
 MX系列功能代碼二碼

5. 接頭形式
B
 請參閱上表步驟5

噴嘴零件功能說明 / 依噴嘴功能及需求條件組合完整的二流體噴嘴型號

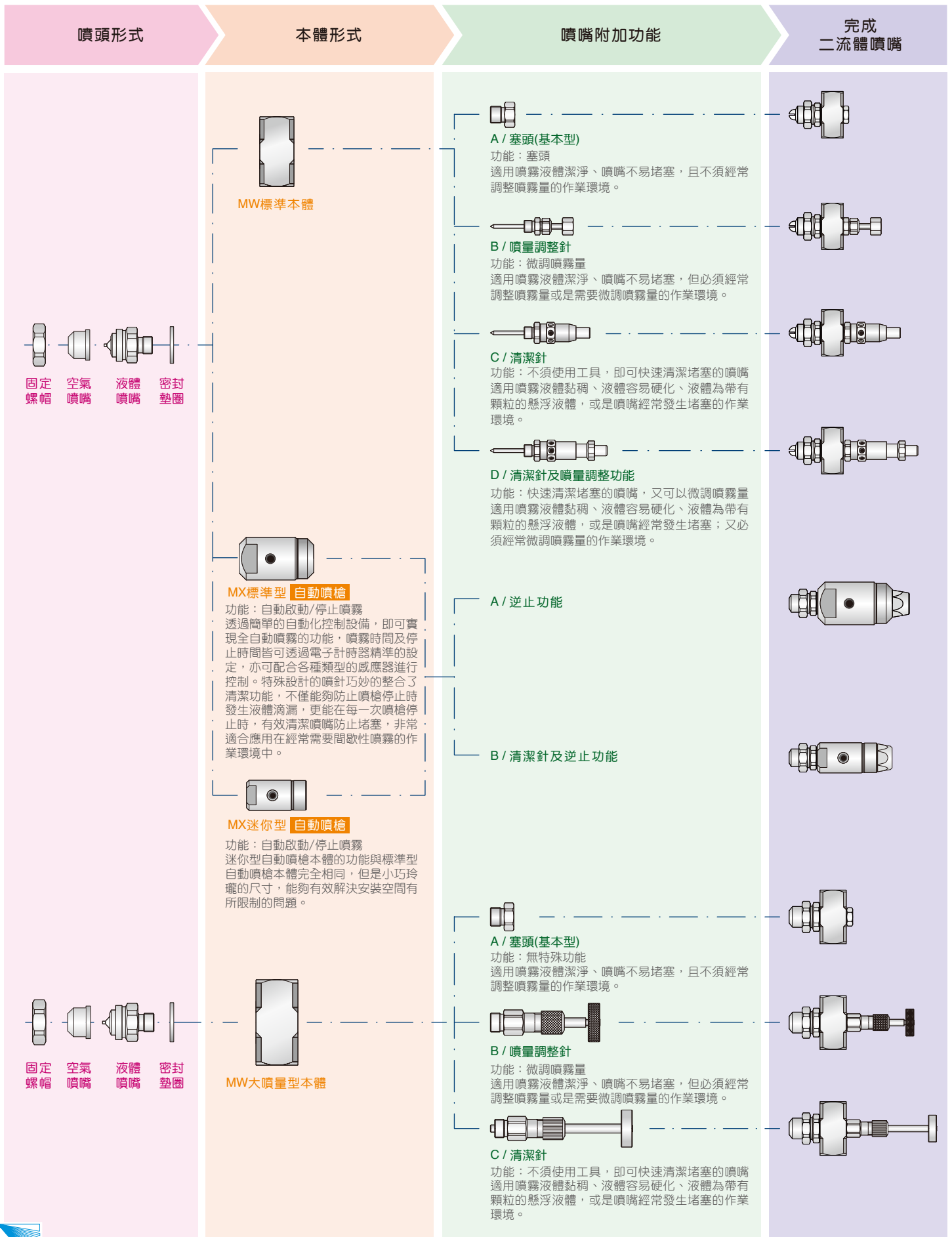

MW二流體噴嘴及MX自動噴槍尺寸圖

MW(1/4"標準型)二流體噴嘴 & MX自動噴槍尺寸圖

請先選擇噴嘴本體形式及附加功能，再依噴頭形式對照正確噴嘴尺寸(參照右表尺寸表)

MW標準本體 / 塞頭(基本型)

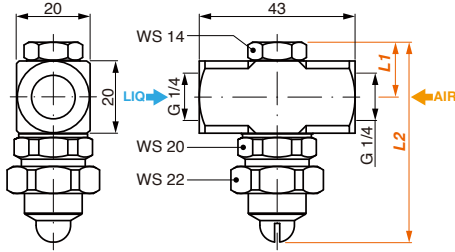

MW標準本體 / 噴量調整針

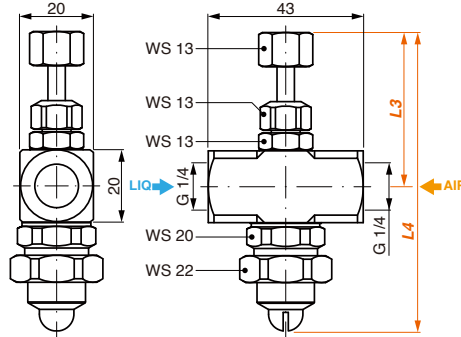

MW標準本體 / 清潔針

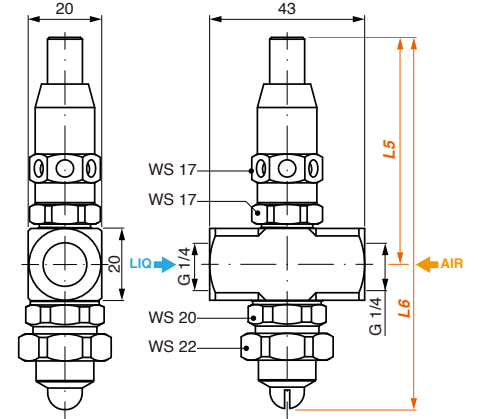

MW標準本體 / 噴量調整功能及清潔針

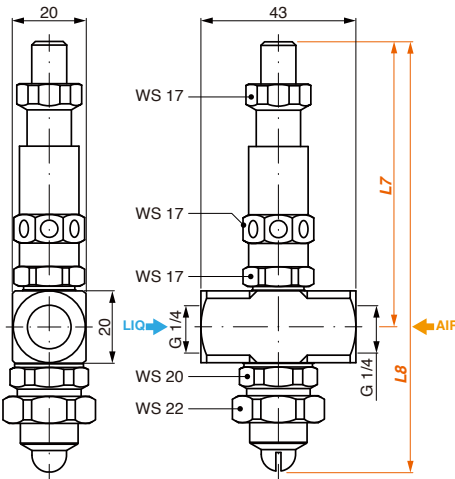

MX自動噴槍本體 / 標準型

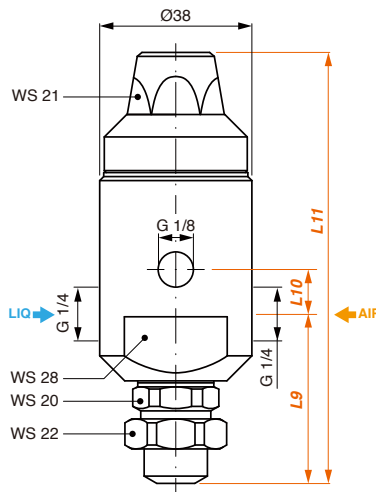

MX自動噴槍本體 / 迷你型

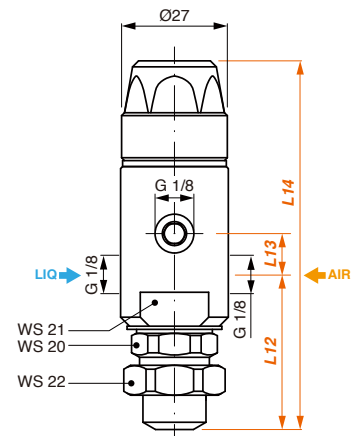

MW(1/2"大噴量型)二流體噴嘴尺寸圖

請先選擇噴嘴本體形式及附加功能，再依噴頭形式對照正確噴嘴尺寸(參照右表下方『1/2"大噴量型』尺寸表)

MW大噴量型本體(1/2") / 塞頭(基本型)

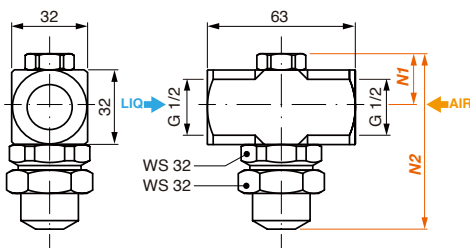

MW大噴量型本體(1/2") / 噴量調整針

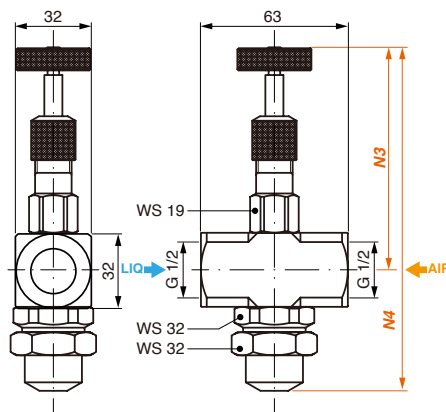

MW大噴量型本體(1/2") / 清潔針

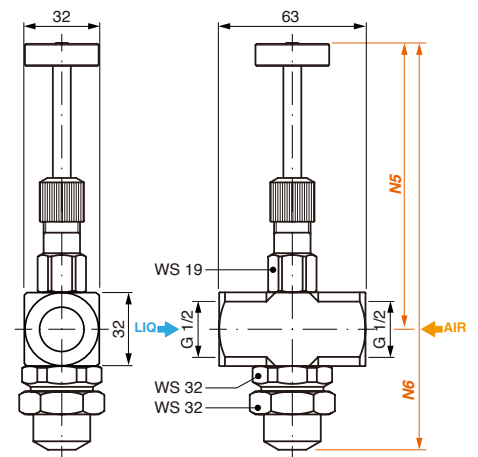

噴頭型號	尺寸代碼														
	L1	L2	L3	L4	L5	L6	L7	L8	L9	L10	L11	L12	L13	L14	
實心圓錐形 (壓力式內混型)	SUB 1520	15.0	51.0	43.0	79.0	63.0	99.0	79.5	115.5	41.0	13.0	108.0	39.0	11.5	93.0
	SUB 1670	15.0	51.0	43.0	79.0	63.0	99.0	79.5	115.5	41.0	13.0	108.0	39.0	11.5	93.0
	SUB 2142	15.0	51.0	43.0	79.0	63.0	99.0	79.5	115.5	41.0	13.0	108.0	39.0	11.5	93.0
	SUC 2376	15.0	51.0	43.0	79.0	63.0	99.0	79.5	115.5	41.0	13.0	108.0	39.0	11.5	93.0
	SUC 2690	15.0	51.0	43.0	79.0	63.0	99.0	79.5	115.5	41.0	13.0	108.0	39.0	11.5	93.0
	SUC 3129	15.0	51.0	43.0	79.0	63.0	99.0	79.5	115.5	41.0	13.0	108.0	39.0	11.5	93.0
廣角實心圓錐形 (壓力式內混型)	SUL 1640	15.0	50.5	43.0	78.5	63.0	98.5	79.5	115.0	40.5	13.0	107.5	38.5	11.5	92.5
	SUM 2220	15.0	52.5	43.0	80.5	63.0	100.5	79.5	117.0	42.5	13.0	109.5	40.5	11.5	94.5
	SUL 2330	15.0	52.5	43.0	80.5	63.0	100.5	79.5	117.0	42.5	13.0	109.5	40.5	11.5	94.5
	SUM 2460	15.0	52.5	43.0	80.5	63.0	100.5	79.5	117.0	42.5	13.0	109.5	40.5	11.5	94.5
	SUM 2860	15.0	52.5	43.0	80.5	63.0	100.5	79.5	117.0	42.5	13.0	109.5	40.5	11.5	94.5
	SUQ 3140	15.0	55.0	43.0	83.0	63.0	103.0	79.5	119.5	45.0	13.0	112.0	43.0	11.5	97.0
扇形 (壓力式內混型)	SUU 2101	15.0	51.7	43.0	79.7	63.0	99.7	79.5	116.2	41.7	13.0	108.7	39.7	11.5	93.7
	SUU 2160	15.0	51.7	43.0	79.7	63.0	99.7	79.5	116.2	41.7	13.0	108.7	39.7	11.5	93.7
	SUM 2167	15.0	51.7	43.0	79.7	63.0	99.7	79.5	116.2	41.7	13.0	108.7	39.7	11.5	93.7
	SUU 2171	15.0	51.7	43.0	79.7	63.0	99.7	79.5	116.2	41.7	13.0	108.7	39.7	11.5	93.7
	SUM 2320	15.0	56.0	43.0	84.0	63.0	104.0	79.5	120.5	46.0	13.0	113.0	44.0	11.5	98.0
	SUM 2600	15.0	56.0	43.0	84.0	63.0	104.0	79.5	120.5	46.0	13.0	113.0	44.0	11.5	98.0
實心圓錐形 (虹吸式內混型)	SUQ 2700	15.0	56.0	43.0	84.0	63.0	104.0	79.5	120.5	46.0	13.0	113.0	44.0	11.5	98.0
	SUQ 3126	15.0	56.0	43.0	84.0	63.0	104.0	79.5	120.5	46.0	13.0	113.0	44.0	11.5	98.0
	SUC 1120	15.0	46.0	43.0	74.0	63.0	94.0	79.5	110.5	36.0	13.0	103.0	34.0	11.5	88.0
	SUC 1190	15.0	46.0	43.0	74.0	63.0	94.0	79.5	110.5	36.0	13.0	103.0	34.0	11.5	88.0
	SUC 1200	15.0	46.0	43.0	74.0	63.0	94.0	79.5	110.5	36.0	13.0	103.0	34.0	11.5	88.0
	SUC 1290	15.0	46.0	43.0	74.0	63.0	94.0	79.5	110.5	36.0	13.0	103.0	34.0	11.5	88.0
扇形 (虹吸式內混型)	SUC 2105	15.0	46.0	43.0	74.0	63.0	94.0	79.5	110.5	36.0	13.0	103.0	34.0	11.5	88.0
	SUC 2180	15.0	46.0	43.0	74.0	63.0	94.0	79.5	110.5	36.0	13.0	103.0	34.0	11.5	88.0
	SUQ 0860	15.0	51.7	43.0	79.7	63.0	99.7	79.5	116.2	41.7	13.0	108.7	39.7	11.5	93.7
	SUQ 1280	15.0	56.0	43.0	84.0	63.0	104.0	79.5	120.5	46.0	13.0	113.0	44.0	11.5	98.0
	SUQ 1370	15.0	56.0	43.0	84.0	63.0	104.0	79.5	120.5	46.0	13.0	113.0	44.0	11.5	98.0
	SUQ 1540	15.0	56.0	43.0	84.0	63.0	104.0	79.5	120.5	46.0	13.0	113.0	44.0	11.5	98.0
扇形 (壓力式外混型)	SUL 2110	15.0	49.0	43.0	77.0	63.0	97.0	79.5	113.5	39.0	13.0	106.0	37.0	11.5	91.0
	SUT 2111	15.0	51.0	43.0	79.0	63.0	99.0	79.5	115.5	41.0	13.0	108.0	39.0	11.5	93.0
	SUR 2166	15.0	49.0	43.0	77.0	63.0	97.0	79.5	113.5	39.0	13.0	106.0	37.0	11.5	91.0
	SUV 2172	15.0	51.0	43.0	79.0	63.0	99.0	79.5	115.5	41.0	13.0	108.0	39.0	11.5	93.0
	SUS 2330	15.0	49.0	43.0	77.0	63.0	97.0	79.5	113.5	39.0	13.0	106.0	37.0	11.5	91.0
	SUV 2331	15.0	51.0	43.0	79.0	63.0	99.0	79.5	115.5	41.0	13.0	108.0	39.0	11.5	93.0
	SUQ 2520	15.0	49.0	43.0	77.0	63.0	97.0	79.5	113.5	39.0	13.0	106.0	37.0	11.5	91.0
	SUV 2521	15.0	51.0	43.0	79.0	63.0	99.0	79.5	115.5	41.0	13.0	108.0	39.0	11.5	93.0
	SUT 2680	15.0	49.0	43.0	77.0	63.0	97.0	79.5	113.5	39.0	13.0	106.0	37.0	11.5	91.0
	SUV 2681	15.0	51.0	43.0	79.0	63.0	99.0	79.5	115.5	41.0	13.0	108.0	39.0	11.5	93.0
	SUN 3101	15.0	49.0	43.0	77.0	63.0	97.0	79.5	113.5	39.0	13.0	106.0	37.0	11.5	91.0
	SUN 3102	15.0	49.0	43.0	77.0	63.0	97.0	79.5	113.5	39.0	13.0	106.0	37.0	11.5	91.0
	SUW 3141	15.0	51.0	43.0	79.0	63.0	99.0	79.5	115.5	41.0	13.0	108.0	39.0	11.5	93.0
	SUN 3175	15.0	49.0	43.0	77.0	63.0	97.0	79.5	113.5	39.0	13.0	106.0	37.0	11.5	91.0
SUN 3280	15.0	49.0	43.0	77.0	63.0	97.0	79.5	113.5	39.0	13.0	106.0	37.0	11.5	91.0	

噴頭型號	尺寸代碼						噴頭型式
	N1	N2	N3	N4	N5	N6	
1/2" 大噴量型	SUL 3316	23.0	87.3	96.0	160.3	124.0	188.3
	SUL 3192	23.0	87.3	96.0	160.3	124.0	188.3
	SUL 3300	23.0	87.3	96.0	160.3	124.0	188.3
	SUM 3740	23.0	87.3	96.0	160.3	124.0	188.3
	SUB 3230	23.0	76.3	96.0	149.3	124.0	177.3
	SUB 3740	23.0	76.3	96.0	149.3	124.0	177.3
SUM 3184	23.0	87.3	96.0	160.3	124.0	188.3	
SUQ 3740	23.0	87.3	96.0	160.3	124.0	188.3	
SUM 4145	23.0	81.3	96.0	154.3	124.0	182.3	
SUZ 3460	23.0	81.3	96.0	154.3	124.0	182.3	
SUC 2230	23.0	81.3	96.0	154.3	124.0	182.3	