

# 壓力式

# 內部混合型噴頭 \ 廣角實心圓錐形

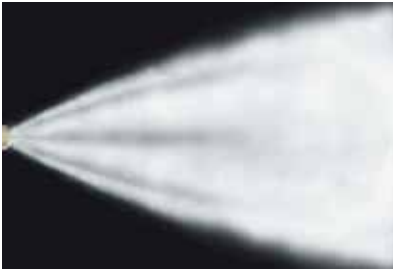

廣角實心圓錐形噴嘴，屬於壓力型內混式，液體必須經由加壓後輸送至噴嘴，液體與壓縮空氣先在噴嘴內部的混合室(Mixing Chamber)均勻混合，再經由噴嘴噴出，內部混合式噴嘴的最大優點是霧化液滴微小均勻，適用在低黏度、不易結晶的液體噴霧應用。

**典型應用** 產品塗佈、產品冷卻、環境加濕、消毒殺菌

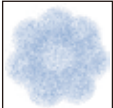

噴霧斷面

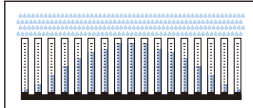

流量分布：標準凸形分布

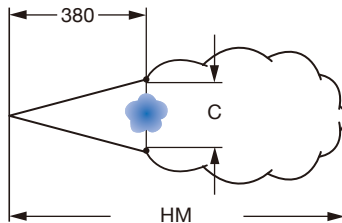

噴頭型號	空氣壓力(bar)												參考數據				
	0.7		2.0		3.0		4.0		5.0		6.0		空氣壓力	液體壓力	參考噴幅		
	噴霧量 l/hour	氣體消耗量 NI/min	噴霧量 l/hour	氣體消耗量 NI/min	噴霧量 l/hour	氣體消耗量 NI/min	噴霧量 l/hour	氣體消耗量 NI/min	噴霧量 l/hour	氣體消耗量 NI/min	噴霧量 l/hour	氣體消耗量 NI/min			C	HM	
<b>SUL 1640</b>	0.6	5.3	10.2	1.5	8.1	16.4	2.4	8.9	22.0	3.1	10.5	24.0	0.7	0.7	230	1500	
	0.7	4.3	12.2	1.8	6.6	21.0	2.7	8.1	26.0	3.4	9.7	28.0	1.4	1.5	240	1800	
	0.9	3.0	14.2	2.1	4.9	25.0	3.0	6.4	30.0	3.9	7.8	36.0	1.8	2.0	250	2100	
	1.0	1.7	17.0	2.4	3.2	29.0	3.2	4.9	34.0	4.2	6.1	42.0	3.0	3.0	260	2700	
<b>Ln XMW 5001</b>	-	-	-	-	-	-	-	3.4	4.2	37.0	4.6	4.4	47.0	3.9	4.0	300	4000
<b>An XMW 4010</b>	-	-	-	-	-	-	-	3.5	3.4	40.0	4.9	2.8	54.0	-	-	-	-
<b>SUM 2220</b>	0.9	7.0	50.0	2.0	18.5	68.0	2.8	25.0	84.0	3.7	31.0	96.0	-	-	-	-	
	1.0	2.1	62.0	2.1	15.1	76.0	3.0	22.0	92.0	3.8	28.0	105	0.9	0.7	310	1800	
	-	-	-	2.2	11.7	85.0	3.1	18.5	101	3.9	26.0	113	1.7	1.5	330	2400	
	-	-	-	-	-	-	3.2	15.1	109	4.1	23.0	122	2.1	2.0	330	3200	
	-	-	-	-	-	-	3.4	12.1	119	4.2	20.0	130	3.2	3.0	340	4100	
<b>Ln XMW 5003</b>	-	-	-	-	-	-	-	3.5	9.1	130	4.6	13.6	153	4.1	4.0	370	5900
<b>An XMW 4011</b>	-	-	-	-	-	-	-	3.7	6.1	142	4.9	6.8	183	-	-	-	-
<b>SUL 2330</b>	1.1	12.3	40.0	2.7	21.0	69.0	4.2	19.3	100	5.6	22.0	130	-	-	-	-	
	1.3	9.9	45.0	3.0	16.3	78.0	4.6	14.6	113	6.0	17.6	142	1.5	0.7	230	2700	
	1.4	7.9	50.0	3.2	12.3	86.0	4.9	10.8	124	6.3	14.0	152	3.0	1.5	240	4600	
	1.5	6.1	54.0	3.4	10.7	91.0	5.3	8.1	135	6.7	11.4	163	3.4	2.0	240	5500	
	1.7	4.9	58.0	3.5	9.3	94.0	5.6	6.2	146	7.0	9.1	174	5.3	3.0	250	7300	
<b>Ln XMW 5003</b>	1.8	3.9	62.0	3.9	6.4	105	6.0	4.9	157	-	-	-	6.3	4.0	300	9400	
<b>An XMW 4013</b>	2.0	3.1	67.0	4.2	4.7	115	6.3	4.0	167	-	-	-	-	-	-	-	
<b>SUM 2460</b>	0.7	24.0	32.0	2.1	33.0	66.0	2.8	52.0	65.0	3.7	63.0	68.0	-	-	-	-	
	0.9	13.6	44.0	2.2	26.0	78.0	3.0	46.0	76.0	3.8	58.0	79.0	0.9	0.7	360	2100	
	1.0	7.6	57.0	2.4	18.9	89.0	3.1	39.0	87.0	3.9	52.0	101	1.5	1.5	370	3200	
	-	-	-	2.5	11.7	100	3.2	33.0	99.0	4.2	41.0	111	2.4	2.0	370	4100	
	-	-	-	-	-	-	3.4	26.0	110	4.6	27.0	138	3.2	3.0	380	5000	
<b>Ln XMW 5004</b>	-	-	-	-	-	-	-	3.5	19.5	122	4.9	15.9	166	3.9	4.0	390	6800
<b>An XMW 4011</b>	-	-	-	-	-	-	-	3.7	13.2	133	-	-	-	-	-	-	-
<b>SUM 2860</b>	1.3	36.0	85.0	3.1	53.0	156	4.2	64.0	197	5.6	74.0	245	-	-	-	-	
	1.5	29.0	102	3.2	50.0	163	4.9	51.0	230	6.0	68.0	260	2.0	0.7	330	5500	
	1.8	23.0	117	3.4	47.0	170	5.6	40.0	265	6.3	62.0	280	3.0	1.5	340	6400	
	2.0	19.7	125	3.5	45.0	177	6.0	34.0	285	6.7	56.0	295	3.9	2.0	370	8200	
	2.1	16.7	133	3.9	38.0	194	6.3	28.0	300	7.0	51.0	315	6.0	3.0	380	9100	
<b>Ln XMW 5004</b>	2.3	14.0	142	4.6	25.0	230	6.7	22.0	320	-	-	-	6.3	4.0	410	10400	
<b>An XMW 4012</b>	2.4	11.4	149	4.9	18.5	245	7.0	17.8	335	-	-	-	-	-	-	-	
<b>SUQ 3140</b>	1.7	25.0	156	3.4	50.0	250	4.6	62.0	320	6.0	93.0	395	2.0	0.7	460	5500	
	1.8	19.7	167	3.5	43.0	260	4.9	47.0	345	6.3	77.0	425	3.2	1.5	470	6400	
	2.0	15.1	178	3.7	41.0	275	5.3	36.0	375	6.7	62.0	460	3.9	2.0	510	7300	
	2.1	11.4	193	3.9	27.0	300	5.6	26.0	405	7.0	52.0	495	5.3	3.0	530	7900	
	2.3	7.6	205	4.1	23.0	310	6.0	18.9	435	-	-	-	6.3	4.0	580	9800	
<b>Ln XMW 5005</b>	-	-	-	4.2	18.9	320	6.3	13.6	460	-	-	-	-	-	-	-	
<b>An XMW 4014</b>	-	-	-	4.4	15.9	335	-	-	-	-	-	-	-	-	-	-	



**洽詢方式說明** 範例 MWL 1640 B1BB

- 1. 本體形式**  
MW  
請參閱P10說明
- 2. 二流體噴頭組**  
L 1640  
請參閱上表
- 3. 材質**  
B1  
請參閱P10說明
- 4. 附加功能**  
B  
請參閱P10說明
- 5. 接頭形式**  
B  
請參閱P10說明

SUL 1640 → L 1640  
選定噴頭型號SUL 1640  
請將SU(Set Up) 移除  
使用型號為L 1640。

請參照下表，依噴嘴功能及需求條件組合完整的二流體噴嘴型號

# 編碼方式說明

1. 選擇搭配本體形式	2. 選擇適合的噴頭形式 螺帽 空氣噴嘴 液體噴嘴 密封墊圈	3. 選擇噴嘴材質	4. 選擇噴嘴附加功能 MW系列功能代碼一碼 MX系列功能代碼二碼	5. 選擇噴嘴接頭形式	完成二流體噴嘴
<b>1/4"</b> <b>MW</b> 標準本體 	標準實心圓錐形 ..... P.12 壓力式 內部混合型  廣角實心圓錐形 ..... P.13 壓力式 內部混合型  扇形 ..... P.14 壓力式 內部混合型 	<b>B1 / SUS303</b> <b>B3 / SUS316</b> <b>D1 / PVC</b> <b>E6 / LUCITE</b> <b>T8 / 黃銅鍍銀</b>	<b>A / 塞頭(基本型)</b>  <b>B / 噴量調整針</b>  <b>C / 清潔針</b>  <b>D / 清潔針及噴量調整功能</b> 	<b>B / BSP Female (EU)</b> <b>N / NPT Female (US)</b>	
<b>1/4"</b> <b>MX</b> 自動噴槍本體 標準型 	實心圓錐形 ..... P.15 虹吸式 內部混合型  扇形 ..... P.15 虹吸式 內部混合型 	<b>B1 / SUS303</b> <b>B3 / SUS316</b> <b>T8 / 黃銅鍍銀</b>	<b>S / 標準型</b> <b>U / 標準型 單一氣源入口</b> <b>A / 逆止功能</b>	<b>B / BSP Female (EU)</b> <b>N / NPT Female (US)</b>	
<b>1/8"</b> <b>MX</b> 自動噴槍本體 迷你型 	扇形 ..... P.16 壓力式 外部混合型 	<b>T8 / 黃銅鍍銀</b>	<b>M / 迷你型</b> <b>N / 迷你型 單一氣源入口</b>	<b>N / NPT Female (US)</b>	
<b>1/2"</b> <b>MW</b> 大噴量型本體 	廣角實心圓錐形 ..... P.19 壓力式 內混型  實心圓錐形 ..... P.19 壓力式 內混型  扇形 ..... P.19 壓力式 內混型  扇形 ..... P.20 壓力式 外混型  空心圓錐形 ..... P.20 壓力式 內混型  實心圓錐形 ..... P.20 虹吸式 內混型 	<b>B1 / SUS303</b> <b>B3 / SUS316</b> <b>D1 / PVC</b> <b>T8 / 黃銅鍍銀</b>	<b>A / 塞頭(基本型)</b>  <b>B / 噴量調整針</b>  <b>C / 清潔針</b> 	<b>B / BSP Female (EU)</b> <b>N / NPT Female (US)</b>	

### 洽詢方式說明

範例 MXB 1520 B1SAB

**1. 本體形式**  
**MX**  
 請參閱上表步驟1

**2. 二流體噴頭組**  
**B 1520**  
 請參閱上表步驟2  
**SUB 1520 → B 1520**

- ① 選定《二流體噴頭組》型號SUB 1520
- ② 將SU(Set Up) 移除，使用型號為B 1520。

**3. 材質**  
**B1**  
 請參閱上表步驟3

**4. 附加功能**  
**SA**  
 請參閱上表步驟4  
 MW系列功能代碼一碼  
 MX系列功能代碼二碼

**5. 接頭形式**  
**B**  
 請參閱上表步驟5

## 噴嘴零件功能說明 / 依噴嘴功能及需求條件組合完整的二流體噴嘴型號

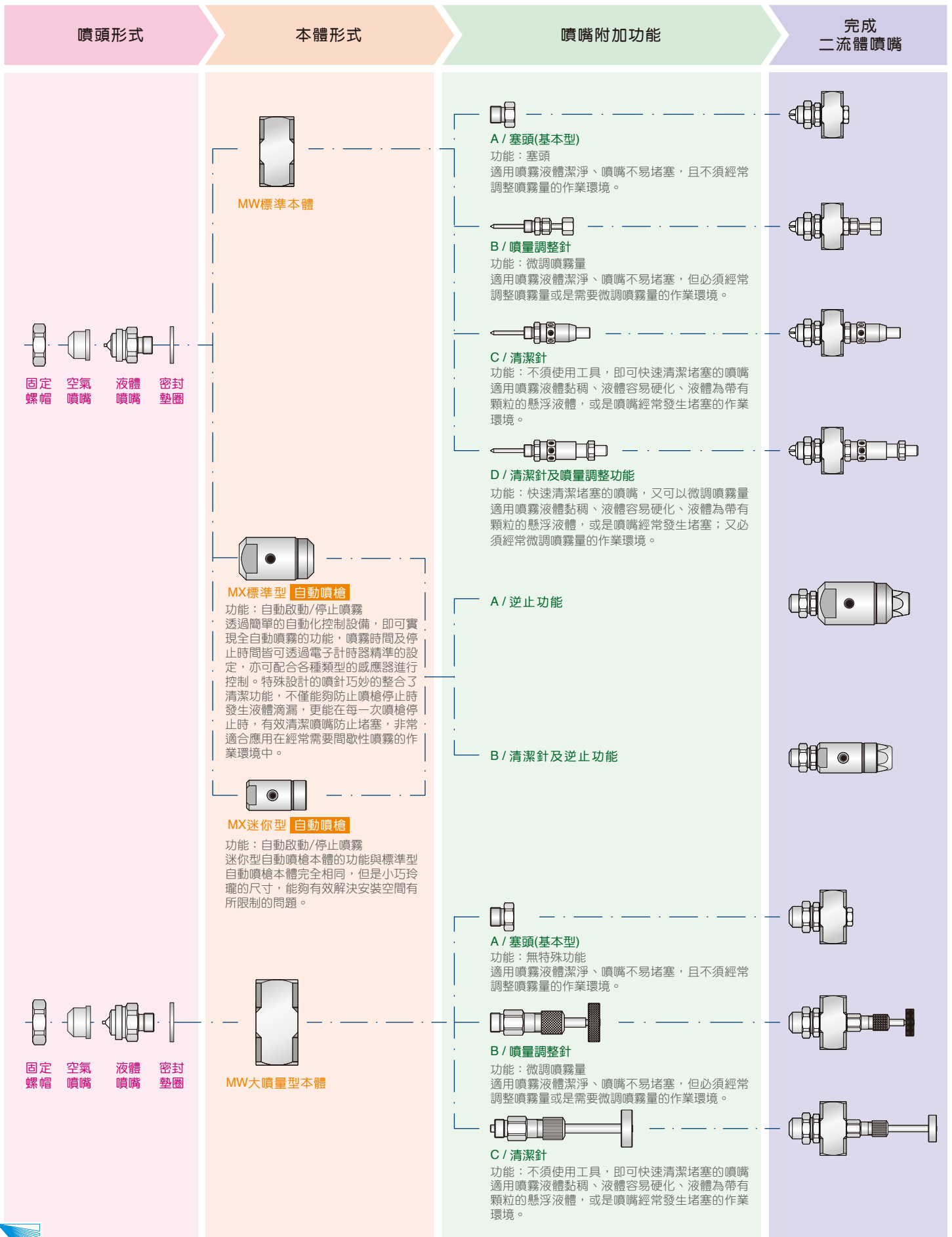

# MW二流體噴嘴及MX自動噴槍尺寸圖

## MW(1/4"標準型)二流體噴嘴 & MX自動噴槍尺寸圖

請先選擇噴嘴本體形式及附加功能，再依噴頭形式對照正確噴嘴尺寸(參照右表尺寸表)

MW標準本體 / 塞頭(基本型)

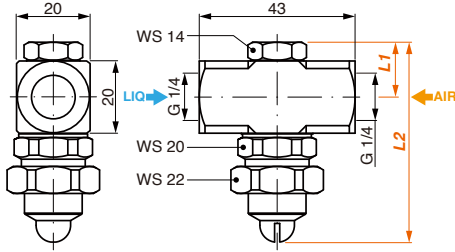

MW標準本體 / 噴量調整針

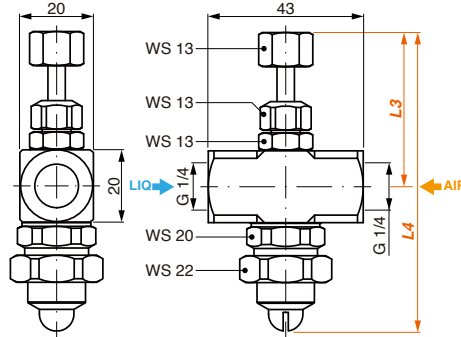

MW標準本體 / 清潔針

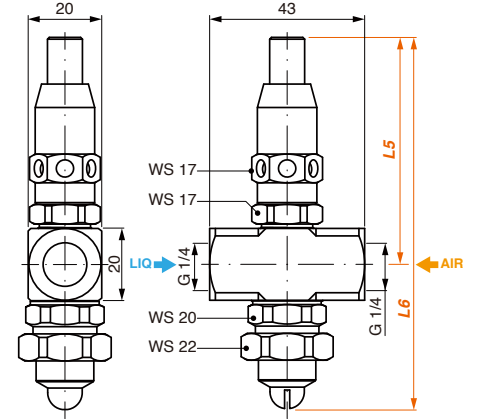

MW標準本體 / 噴量調整功能及清潔針

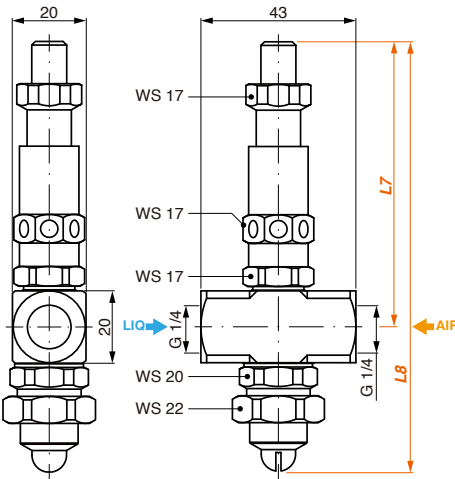

MX自動噴槍本體 / 標準型

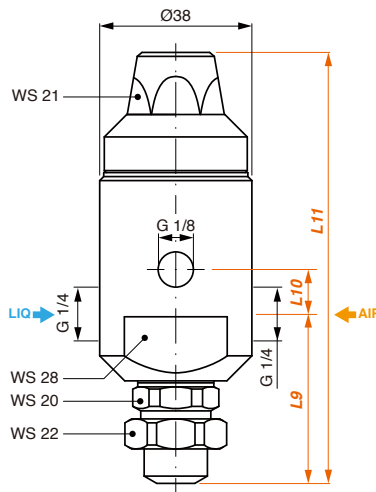

MX自動噴槍本體 / 迷你型

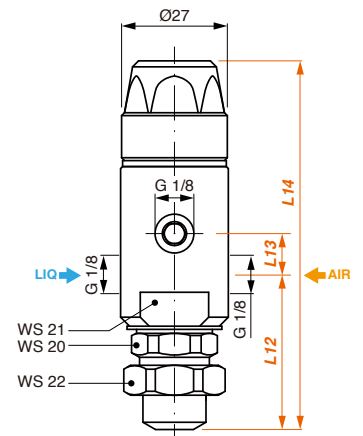

## MW(1/2"大噴量型)二流體噴嘴尺寸圖

請先選擇噴嘴本體形式及附加功能，再依噴頭形式對照正確噴嘴尺寸(參照右表下方『1/2"大噴量型』尺寸表)

MW大噴量型本體(1/2") / 塞頭(基本型)

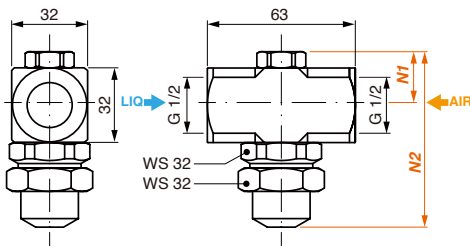

MW大噴量型本體(1/2") / 噴量調整針

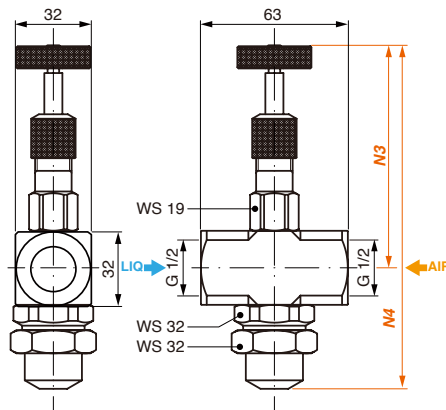

MW大噴量型本體(1/2") / 清潔針

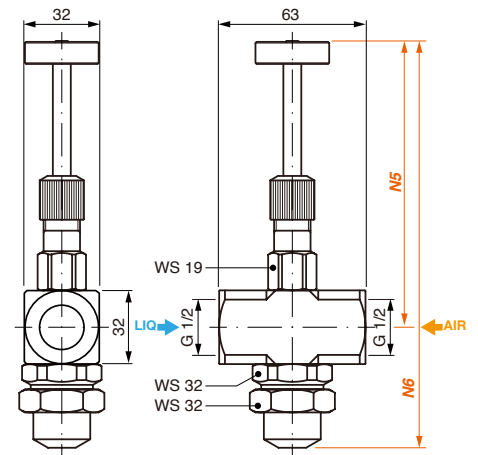

噴頭型號	尺寸代碼														
	L1	L2	L3	L4	L5	L6	L7	L8	L9	L10	L11	L12	L13	L14	
實心圓錐形 (壓力式內混型)	SUB 1520	15.0	51.0	43.0	79.0	63.0	99.0	79.5	115.5	41.0	13.0	108.0	39.0	11.5	93.0
	SUB 1670	15.0	51.0	43.0	79.0	63.0	99.0	79.5	115.5	41.0	13.0	108.0	39.0	11.5	93.0
	SUB 2142	15.0	51.0	43.0	79.0	63.0	99.0	79.5	115.5	41.0	13.0	108.0	39.0	11.5	93.0
	SUC 2376	15.0	51.0	43.0	79.0	63.0	99.0	79.5	115.5	41.0	13.0	108.0	39.0	11.5	93.0
	SUC 2690	15.0	51.0	43.0	79.0	63.0	99.0	79.5	115.5	41.0	13.0	108.0	39.0	11.5	93.0
	SUC 3129	15.0	51.0	43.0	79.0	63.0	99.0	79.5	115.5	41.0	13.0	108.0	39.0	11.5	93.0
廣角實心圓錐形 (壓力式內混型)	SUL 1640	15.0	50.5	43.0	78.5	63.0	98.5	79.5	115.0	40.5	13.0	107.5	38.5	11.5	92.5
	SUM 2220	15.0	52.5	43.0	80.5	63.0	100.5	79.5	117.0	42.5	13.0	109.5	40.5	11.5	94.5
	SUL 2330	15.0	52.5	43.0	80.5	63.0	100.5	79.5	117.0	42.5	13.0	109.5	40.5	11.5	94.5
	SUM 2460	15.0	52.5	43.0	80.5	63.0	100.5	79.5	117.0	42.5	13.0	109.5	40.5	11.5	94.5
	SUM 2860	15.0	52.5	43.0	80.5	63.0	100.5	79.5	117.0	42.5	13.0	109.5	40.5	11.5	94.5
	SUQ 3140	15.0	55.0	43.0	83.0	63.0	103.0	79.5	119.5	45.0	13.0	112.0	43.0	11.5	97.0
扇形 (壓力式內混型)	SUU 2101	15.0	51.7	43.0	79.7	63.0	99.7	79.5	116.2	41.7	13.0	108.7	39.7	11.5	93.7
	SUU 2160	15.0	51.7	43.0	79.7	63.0	99.7	79.5	116.2	41.7	13.0	108.7	39.7	11.5	93.7
	SUM 2167	15.0	51.7	43.0	79.7	63.0	99.7	79.5	116.2	41.7	13.0	108.7	39.7	11.5	93.7
	SUU 2171	15.0	51.7	43.0	79.7	63.0	99.7	79.5	116.2	41.7	13.0	108.7	39.7	11.5	93.7
	SUM 2320	15.0	56.0	43.0	84.0	63.0	104.0	79.5	120.5	46.0	13.0	113.0	44.0	11.5	98.0
	SUM 2600	15.0	56.0	43.0	84.0	63.0	104.0	79.5	120.5	46.0	13.0	113.0	44.0	11.5	98.0
實心圓錐形 (虹吸式內混型)	SUC 2700	15.0	56.0	43.0	84.0	63.0	104.0	79.5	120.5	46.0	13.0	113.0	44.0	11.5	98.0
	SUC 3126	15.0	56.0	43.0	84.0	63.0	104.0	79.5	120.5	46.0	13.0	113.0	44.0	11.5	98.0
	SUC 1120	15.0	46.0	43.0	74.0	63.0	94.0	79.5	110.5	36.0	13.0	103.0	34.0	11.5	88.0
	SUC 1190	15.0	46.0	43.0	74.0	63.0	94.0	79.5	110.5	36.0	13.0	103.0	34.0	11.5	88.0
	SUC 1200	15.0	46.0	43.0	74.0	63.0	94.0	79.5	110.5	36.0	13.0	103.0	34.0	11.5	88.0
	SUC 1290	15.0	46.0	43.0	74.0	63.0	94.0	79.5	110.5	36.0	13.0	103.0	34.0	11.5	88.0
扇形 (虹吸式內混型)	SUC 2105	15.0	46.0	43.0	74.0	63.0	94.0	79.5	110.5	36.0	13.0	103.0	34.0	11.5	88.0
	SUC 2180	15.0	46.0	43.0	74.0	63.0	94.0	79.5	110.5	36.0	13.0	103.0	34.0	11.5	88.0
	SUQ 0860	15.0	51.7	43.0	79.7	63.0	99.7	79.5	116.2	41.7	13.0	108.7	39.7	11.5	93.7
	SUQ 1280	15.0	56.0	43.0	84.0	63.0	104.0	79.5	120.5	46.0	13.0	113.0	44.0	11.5	98.0
	SUQ 1370	15.0	56.0	43.0	84.0	63.0	104.0	79.5	120.5	46.0	13.0	113.0	44.0	11.5	98.0
	SUQ 1540	15.0	56.0	43.0	84.0	63.0	104.0	79.5	120.5	46.0	13.0	113.0	44.0	11.5	98.0
扇形 (壓力式外混型)	SUL 2110	15.0	49.0	43.0	77.0	63.0	97.0	79.5	113.5	39.0	13.0	106.0	37.0	11.5	91.0
	SUT 2111	15.0	51.0	43.0	79.0	63.0	99.0	79.5	115.5	41.0	13.0	108.0	39.0	11.5	93.0
	SUR 2166	15.0	49.0	43.0	77.0	63.0	97.0	79.5	113.5	39.0	13.0	106.0	37.0	11.5	91.0
	SUV 2172	15.0	51.0	43.0	79.0	63.0	99.0	79.5	115.5	41.0	13.0	108.0	39.0	11.5	93.0
	SUS 2330	15.0	49.0	43.0	77.0	63.0	97.0	79.5	113.5	39.0	13.0	106.0	37.0	11.5	91.0
	SUV 2331	15.0	51.0	43.0	79.0	63.0	99.0	79.5	115.5	41.0	13.0	108.0	39.0	11.5	93.0
	SUQ 2520	15.0	49.0	43.0	77.0	63.0	97.0	79.5	113.5	39.0	13.0	106.0	37.0	11.5	91.0
	SUV 2521	15.0	51.0	43.0	79.0	63.0	99.0	79.5	115.5	41.0	13.0	108.0	39.0	11.5	93.0
	SUT 2680	15.0	49.0	43.0	77.0	63.0	97.0	79.5	113.5	39.0	13.0	106.0	37.0	11.5	91.0
	SUV 2681	15.0	51.0	43.0	79.0	63.0	99.0	79.5	115.5	41.0	13.0	108.0	39.0	11.5	93.0
	SUN 3101	15.0	49.0	43.0	77.0	63.0	97.0	79.5	113.5	39.0	13.0	106.0	37.0	11.5	91.0
	SUN 3102	15.0	49.0	43.0	77.0	63.0	97.0	79.5	113.5	39.0	13.0	106.0	37.0	11.5	91.0
	SUW 3141	15.0	51.0	43.0	79.0	63.0	99.0	79.5	115.5	41.0	13.0	108.0	39.0	11.5	93.0
	SUN 3175	15.0	49.0	43.0	77.0	63.0	97.0	79.5	113.5	39.0	13.0	106.0	37.0	11.5	91.0
SUN 3280	15.0	49.0	43.0	77.0	63.0	97.0	79.5	113.5	39.0	13.0	106.0	37.0	11.5	91.0	

噴頭型號	尺寸代碼						噴頭型式		
	N1	N2	N3	N4	N5	N6			
1/2" 大噴量型	SUL 3316	23.0	87.3	96.0	160.3	124.0	188.3	廣角實心圓錐形 (壓力式內混型)	
	SUL 3192	23.0	87.3	96.0	160.3	124.0	188.3		
	SUL 3300	23.0	87.3	96.0	160.3	124.0	188.3		
	SUM 3740	23.0	87.3	96.0	160.3	124.0	188.3		
	SUB 3230	23.0	76.3	96.0	149.3	124.0	177.3		實心圓錐形 (壓力式內混型)
	SUB 3740	23.0	76.3	96.0	149.3	124.0	177.3		
	SUM 3184	23.0	87.3	96.0	160.3	124.0	188.3	扇形 (壓力式內混型)	
	SUQ 3740	23.0	87.3	96.0	160.3	124.0	188.3		
	SUM 4145	23.0	81.3	96.0	154.3	124.0	182.3	扇形 (壓力式外混型)	
	SUZ 3460	23.0	81.3	96.0	154.3	124.0	182.3	空心圓錐形 (壓力式內混型)	
SUC 2230	23.0	81.3	96.0	154.3	124.0	182.3	實心圓錐形 (虹吸式內混型)		