



# UB3 A

ROTATING CLEANING DEVICE  
WITH 3-A CERTIFICATION

# UB3 A SERIES



The rotating tank cleaning nozzle UB3 A is a 3-A<sup>®</sup> certified washing device according to standard 78-03, the US regulation governing the design and production of equipment intended for food contact.

The UB3 A washing devices are made of stainless steel AISI 316L EN 1.4404 and PEEK + 10% PTFE only for the rotating element. This material ensures excellent mechanical characteristics and sliding properties.

The cleaning equipment is suitable for use with products commonly used in CIP (*Clean-In-Place*) processes and compatible with AISI 316L and PEEK. It cannot be used with fluids or substances that could be aggressive towards AISI 316L and PEEK.

The main application of the UB3 A is tank washing in the beverage sector, particularly in the dairy and general food industries. This intended use and compliance with the 3A standard determine two fundamental characteristics of the UB3 A: *ease of assembly and disassembly* and *self-cleaning of internal parts*.



## EASE OF ASSEMBLY AND DISASSEMBLY

The assembly and disassembly phases of the UB3 A are simple and immediate. This ensures the possibility of cleaning and sterilizing all head components whenever necessary.

## SELF-CLEANING OF INTERNAL PARTS

The internal geometries of the device ensure self-cleaning. The head must be installed vertically because horizontal installation does not guarantee complete emptying of the device. The UB3 A can have four flow rates: 100 litres, 75 litres, 50 litres, and 40 litres, all referenced for use at a pressure of 3 bar, the recommended operating pressure by PNR Italia.

## PNR CODING

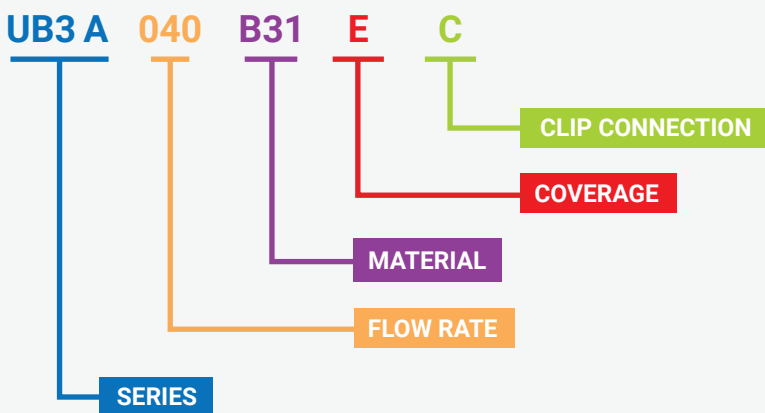

## TECHNICAL DATA

FLOW RATE	40 - 50 - 75 - 100 l/min @ 3 bar
TEMPERATURE MAX	90°C
COMPONENT MATERIAL	AISI 316L stainless steel - PEEK + 10% PTFE
PRESSURE RANGE	1-3 bar
CONNECTION	Clip-on for pipe Ø19 (DIN 11866 Range A)
COVERAGE	360°

# DIMENSIONAL DRAWINGS

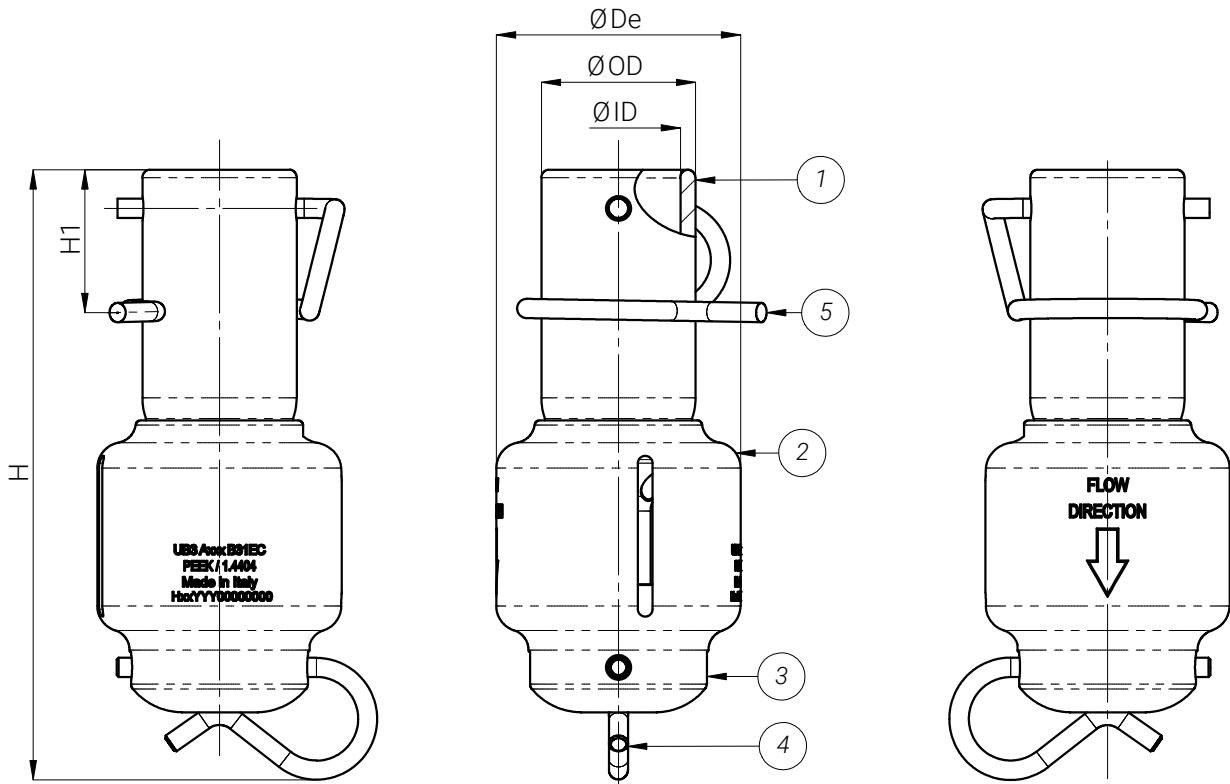

CODE	COVERAGE	FLOW RATE (lpm) @ 3 bar	H	H1	ØDE	ØOD	ØID
UB3 A040 B31EC		40	94	22	38	24	19,3
UB3 A050 B31EC		50	94	22	38	24	19,3
UB3 A075 B31EC		75	94	22	38	24	19,3
UB3 A100 B31EC		100	94	22	38	24	19,3

POSITION	COMPONENTS DESCRIPTION	COMPONENTS MATERIAL
1	Body	AISI 316L stainless steel
2	Rotating head	PEEK + 10% PTFE
3	Stator	AISI 316L stainless steel
4	Stator retaining clip	AISI 316L stainless steel
5	Pipe retaining clip	AISI 316L stainless steel

總代理



思沛雅噴霧器材有限公司

22205 新北市深坑區北深路三段270巷8號3樓(信義財貿工業園區) TEL. 02-8662-6968

Website : www.sprayer.com.tw E-mail : sales@sprayer.com.tw FAX. 02-8662-6967