

UBB

UBB heads are specially designed for applications where chemical attack from strong acids is to be expected, or when contamination to the product being handled is to be excluded, and are therefore entirely made out of PTFE.

Their rotary motion is produced from the reaction forces of their solid stream water jets, which are arranged in such a way that the inner tank surface is thoroughly covered when the head rotor is in motion. The simple design, a two-piece construction, assures for long, maintenance free service. The wide range of capacities and the choice among several spray patterns makes it easy to find the right product to suite a variety of different applications. The codes shown in the capacity table refer to BSP threads.

Our offices can supply coding for products designed with NPT threads.

MATERIAL: E1 PTFE (FDA APPROVED)

BSP / NPT
thread connection

LT: 90° C
LP: 4.0 BAR

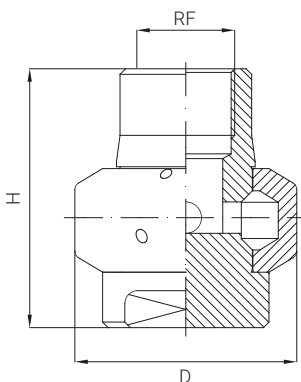
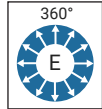
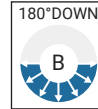
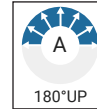

CODE	RF BSP	Capacity at different pressures					Dimensions mm	
		1,5	2,0	2,5	3,0	3,5	H	D
UBB 0003 E1xG	1/2"	21,5	24,7	27,5	30,0	32,3	60	50
UBB 0004 E1xG	3/4"	22,9	26,3	29,3	32,0	34,5	70	60
UBB 0007 E1xG		50,2	57,6	64,1	70,0	75,4		
UBB 0012 E1xG		86,0	98,8	110	120	129		
UBB 0018 E1xG		130	150	167	182	196		
UBB 0020 E1xG	1"	143	165	183	200	215	75	70
UBB 0027 E1xG		197	225	252	275	296		
UBB 0035 E1xG		255	292	325	355	382		
UBB 0039 E1xG	2"	283	325	362	395	425	110	125
UBB 0049 E1xG		355	407	454	495	533		
UBB 0059 E1xG		423	486	541	590	635		
UBB 0069 E1xG		495	568	632	690	743		
UBB 0098 E1xG	3"	706	811	902	985	1061	150	175
UBB 0118 E1xG		846	971	1081	1180	1271		
UBB 0138 E1xG		989	1136	1264	1380	1486		

In order to obtain the complet code of the tank washing head, you need to change the "x" letter, in second to last position, with the corresponding letter concerning the spray coverage, among the ones available.

總代理



思沛雅噴霧器材有限公司

22205 新北市深坑區北深路三段270巷8號3樓 Website : www.sprayer.com.tw
TEL. 02-8662-6968 FAX. 02-8662-6967 E-mail : sales@sprayer.com.tw