



VEM SERIES

STAINLESS STEEL
HYDRAULIC FILTER

SERIE VEM



VEM strainers are specially designed for high particle retention, easy maintenance, and excellent efficiency in harsh operating conditions. Their bowl houses a large cartridge for longer operating life and reduced servicing times.

The tri-clamp connection to the strainer body allows a quick removal with no tools. Removable bottom plug for easy screen cleaning.

The **tri-clamp fitting** guarantees a safe, uniform, and smooth union of the parts and consequent ease of cleaning and minimum risk of residues that can affect the quality of the product.

The tri-clamp connection is often used in systems where it is essential to comply with sanitary standards.

316L stainless steel is highly resistant to corrosion. It does not alter the filtered liquid's color, smell, and taste and is resistant to very high and shallow temperatures.

The quality/price ratio is highly advantageous, thanks to the long operating life of the filter made of 316L stainless steel.

The stainless steel corrosion resistance allows using the VEM filter in saline environments and marine areas, in environments with a high concentration of chemical substances, and in general where adverse operating conditions occur.



PNR CODING

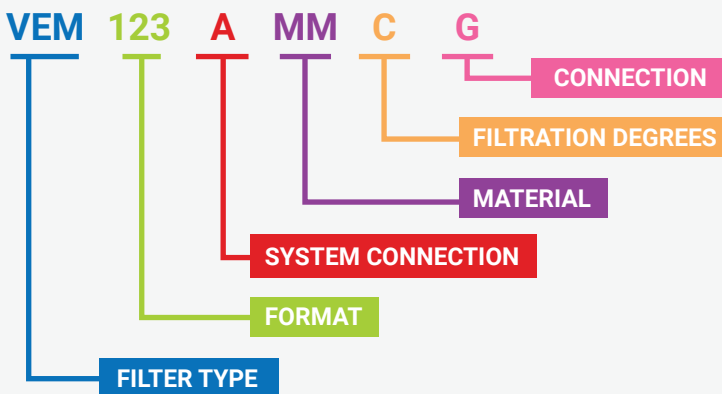

THREAD SIZE	1/2", 3/4", 1"
TRI-CLAMP DIMENSIONS	1-1/2" line, 2" body
WIRE NET MESH SIZE	60-75-100 mesh
MAX WORKING PRESSURE	14 bar
MAX CAPACITY	14 lpm
MATERIAL	AISI 316L
TYPICAL APPLICATION	Filtering before spraying liquids

CODE	RF mm	H mm	H1 mm	L mm	CARTRIDGE	M mesh	kg
VEM 100D B31FG	1/2"	223	195	124	XVE 3210 B31RF	60	1,87
VEM 100E B31FG	3/4"	223	195	124	XVE 3210 B31RF	60	1,87
VEM 100F B31FG	1"	223	195	124	XVE 3210 B31RF	60	1,87
VEM 100D B31BG	1/2"	223	195	124	XVE 3210 B31RB	75	1,87
VEM 100E B31BG	3/4"	223	195	124	XVE 3210 B31RB	75	1,87
VEM 100F B31BG	1"	223	195 </td <td>124</td> <td>XVE 3210 B31RB</td> <td>75</td> <td>1,87</td>	124	XVE 3210 B31RB	75	1,87
VEM 100D B31AG	1/2"	223	195	124	XVE 3210 B31RA	100	1,87
VEM 100E B31AG	3/4"	223	195	124	XVE 3210 B31RA	100	1,87
VEM 100F B31AG	1"	223	195	124	XVE 3210 B31RA	100	1,87
VEM 100H B31FT	TRI-CLAMP	220	192	100	XVE 3210 B31RF	60	1,87
VEM 100H B31BT	TRI-CLAMP	220	192	100	XVE 3210 B31RB	75	1,87
VEM 100H B31AT	TRI-CLAMP	220	192	100	XVE 3210 B31RA	100	1,87

MESH NUMBER	FREE PASSAGE mm
60	0,25
75	0,20
100	0,10

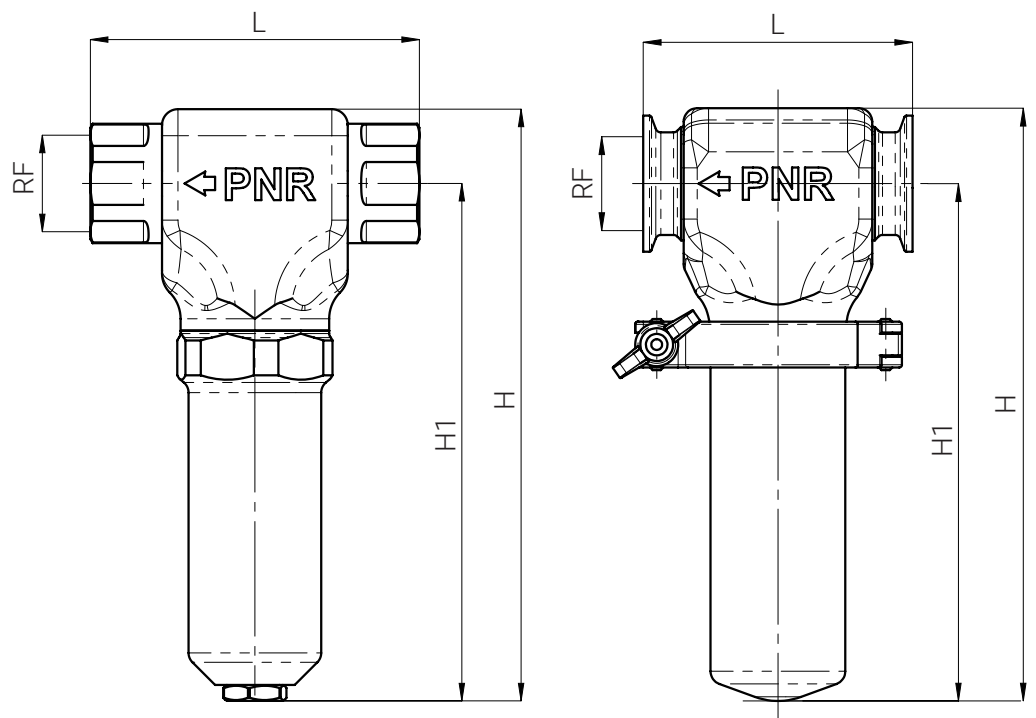

總代理



思沛雅噴霧器材有限公司

222 新北市深坑區北深路三段270巷8號3樓 | 信義財貿工業園區 TEL. 02-8662-6968
Website: www.sprayer.com.tw E-mail: sales@sprayer.com.tw FAX. 02-8662-6967