

Bio 2SB

Scanjet tank cleaning equipment



KEY FEATURES

- + Rotating spray
- + 360 degree spiral cleaning
- + Ideal for small tanks
- + Low pressure
- + Low volume

The Scanjet Bio 2SB is a very efficient replacement to traditional static cleaning devices, it offers 360° impact coverage, self-cleaning and self-draining. Bio 2SB design follow EHEDG and GMP guidelines, it can be supplied with EN10204-2.1, 2.2 or 3.1 material and FDA 21CFR compliance certificates.

Standard surface finish roughness Ra = 0.8 μm (30 μ inch), other standard surfaces are available upon requests.

The Scanjet Bio 2SB-XXX-A (clip-on and weld on versions) has attained 3A certification under sanitary standard 78-01.

This new type of fluid bearing Rotary Spray Head is becoming the first choice for customers looking to improve their CIP tank cleaning systems, saving water and at the same time increase the cleaning efficiency. The Bio 2SB is easy to install and comes with either a pin, weld-on or threaded connection, the life time of fluid bearing cleaning devices is two to three times compared to what traditional ball bearing cleaning devices offer.

The Scanjet Bio 2SB can be used in a wide range of applications such as;

- + Mixing vessels
- + Reactors
- + Yeast tanks
- + IBC's
- + Blending tanks
- + Beverage tanks
- + Dairy tanks
- + Enclosed Cheese Vats



scanjet



總代理

思沛雅噴霧器材有限公司

22205 新北市深坑區北深路三段270巷8號3樓 TEL. 02-8662-6968 FAX. 02-8662-6967
Website : www.sprayernozzle.com.tw E-mail : sales@sprayernozzle.com.tw

Technical performance

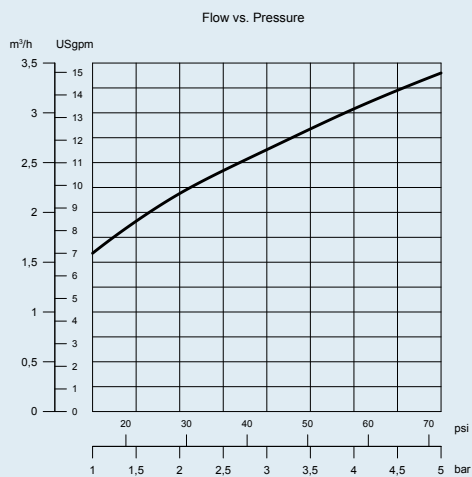

* Clip-on models have approx. 0,5 m³/h higher flow rate

Pressure/Flow

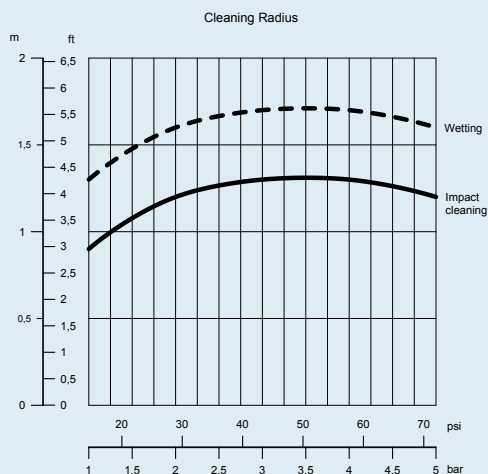

Cleaning radius

Dimensions

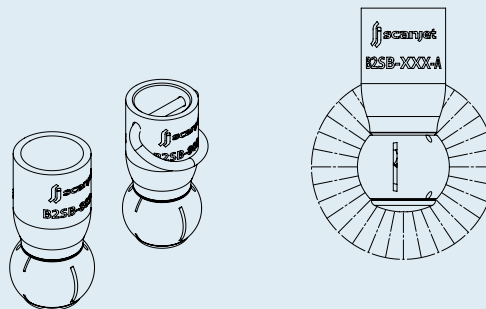
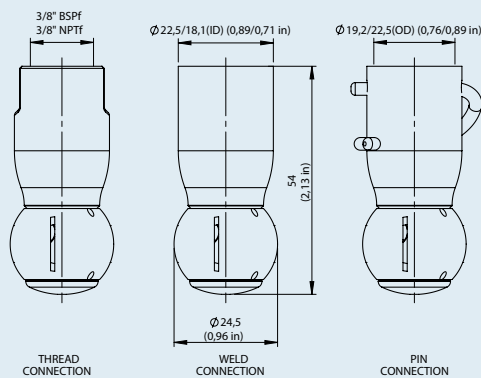

Specifications

Flow	1.6-3.4 m ³ /h (7-15 USpm)
Inlet pressure	1-5 bar (14-72 psi)
Max pressure	5 bar (72 psi)
Recommended pressure	3 bar (43 psi)
Max working temperature	95°C (200° F)
Max ambient temperature	150°C (300° F)
Weight	53-73 g (1.9-2.6 oz)
Connections	3/8" NPT or BSP Weld connection Pin connection
Material	EN1.4404/PEEK 450G
Lubrication	Self lubricated by media



Scanjet Systems AB
P.O. Box 9316
SE-400 97 Göteborg Sweden
Phone +46 31 3387530
Fax +46 31 3387540
E-mail sales@scanjetsystems.com
Web www.scanjetsystems.com



總代理

思沛雅噴霧器材有限公司

22205 新北市深坑區北深路三段270巷8號3樓 TEL. 02-8662-6968 FAX. 02-8662-6967
Website : www.sprayernozzle.com.tw E-mail : sales@sprayernozzle.com.tw