

# SC 30TA

Scanjet tank cleaning equipment

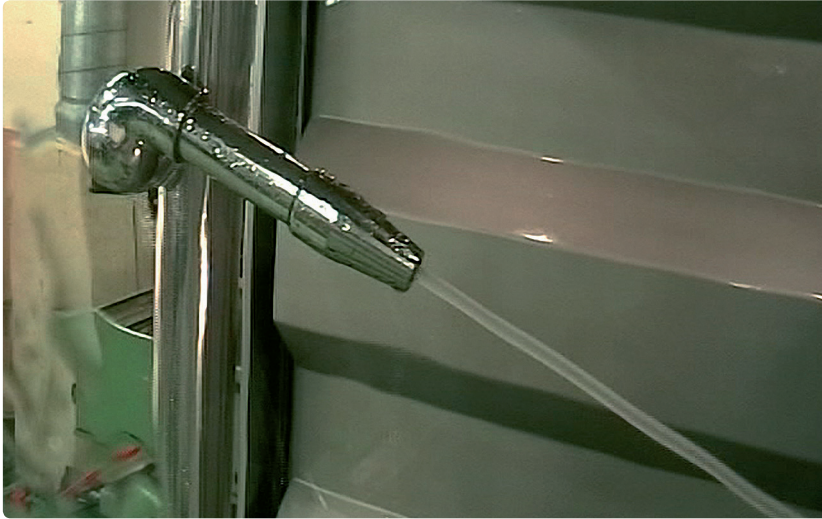

## KEY FEATURES

- + Aseptic
- + Internally and externally polished to 0,8 micron
- + Alcohol filled cofferdam available

SC 30TA is the first single nozzle aseptically designed programmable tank cleaning machine suited to large tank installations. The unit is internally and externally polished to end user specification and can also be delivered with alcohol cofferdams between the drive unit and tank atmosphere.

The single nozzle design delivers a solid and powerful jet with an optimized cleaning result on all tank surfaces. It comprises a unique separated turning and lifting moment with a rapid manual overdrive for sector cleaning setting.

### Quality Control, Compliances & Certifications

The SC 30TA is produced in accordance with ISO 9001 Quality Standards and our certificate of conformity and accreditation is available on request. Additionally, the SC 30TA conforms to United States ASME standards for construction and others are available upon request.

### Typical applications

- + Large process vessels and reactors
- + Large storage tanks
- + Large transportations tanks
- + Juice tanks
- + Beverage tanks

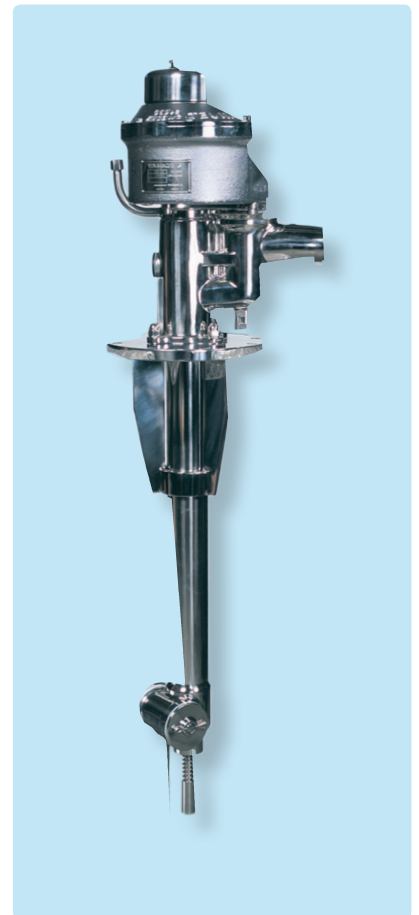

 scanjet



總代理

思沛雅噴霧器材有限公司

22205 新北市深坑區北深路三段270巷8號3樓 TEL. 02-8662-6968 FAX. 02-8662-6967  
Website : [www.sprayernozzle.com.tw](http://www.sprayernozzle.com.tw) E-mail : [sales@sprayernozzle.com.tw](mailto:sales@sprayernozzle.com.tw)

## Technical performance

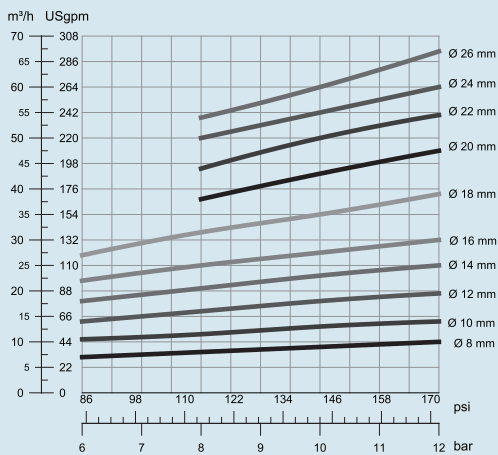

Pressure/Flow

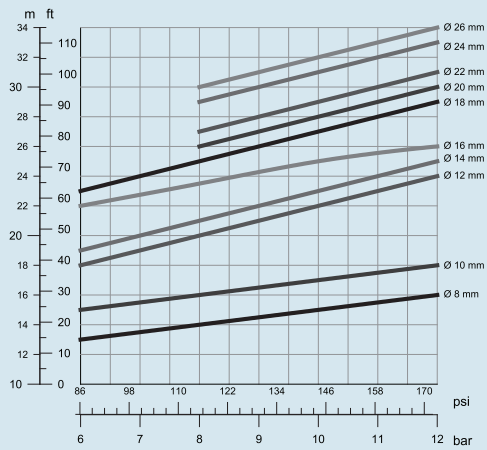

Jet length

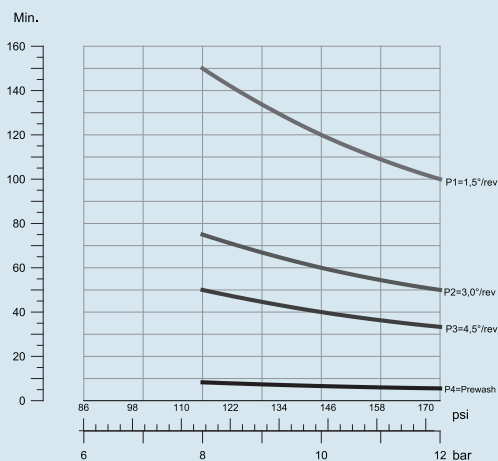

Pattern time

## Dimensions

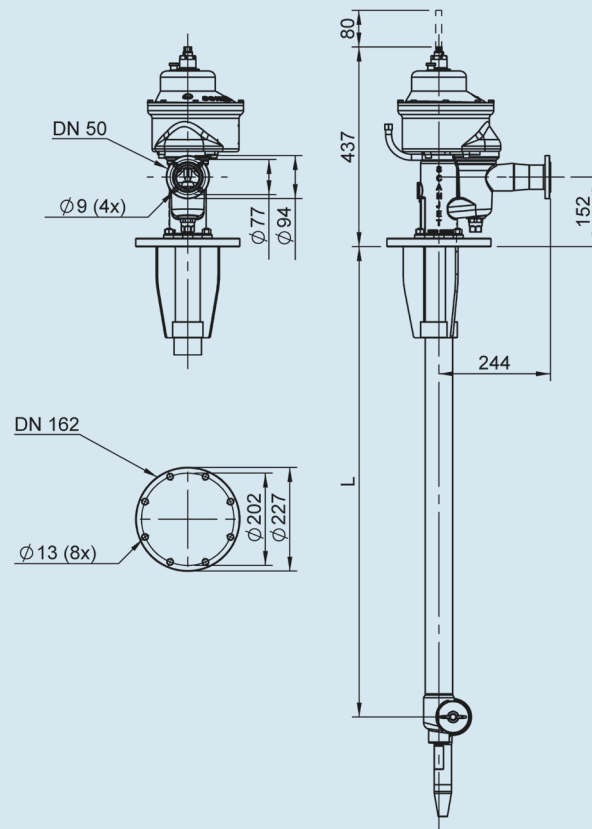

## Specifications

|                                   |                                       |
|-----------------------------------|---------------------------------------|
| Flow                              | 5-65 m <sup>3</sup> /h                |
| Inlet pressure                    | 6-12 bar                              |
| Max pressure                      | 14 bar                                |
| Recommended pressure              | 8 bar                                 |
| Max temperature                   | 95°C                                  |
| Rotation speed                    | 1-1,6 rpm                             |
| Standard length                   | 1000 mm                               |
| Weight                            | 43 kg                                 |
| Per additional meter of main pipe | 10 kg                                 |
| Tank connection                   | DN 162, DIN-11864-BF-A41*1,5-N-1,4404 |
| Inlet connection                  | DN 50, DIN-11864-BF-A41*1,5-N-1,4404  |
| Materials                         | AISI 316, PTFE, Viton                 |
| Lubrication                       | Cleaning Media                        |

We reserve the right to changes without prior notice. Issue 2017-03



Scanjet Systems AB  
 P.O. Box 9316  
 SE-400 97 Göteborg Sweden  
 Phone + 46 31 338 75 30  
 Fax + 46 31 338 75 40  
 E-mail sales@scanjetsystems.com  
 Web www.scanjetsystems.com



總代理

思沛雅噴霧器材有限公司

22205 新北市深坑區北深路三段270巷8號3樓 TEL. 02-8662-6968 FAX. 02-8662-6967

Website : www.sprayernozzle.com.tw E-mail : sales@sprayernozzle.com.tw