

SC 40RT

Scanjet tank cleaning equipment



KEY FEATURES

- + Magnetic drive
- + Rugged construction
- + External drive
- + Easy maintenance
- + High jet impact
- + Easy installation
- + Adjustable speed

The SC 40RT is a dual or four nozzle externally driven automated tank cleaning machine constructed of 316 stainless steel and other highly corrosion resistant materials. It employs a patented magnetic drive transmission thus reducing the need for costly seal replacements and potential failures when used in hazardous environments. The drive mechanism and other major components are external to the tank, this results in easy maintenance and a high level of safety when the cleaning of hazardous products are required.

The SC 40RT is a very rugged and durable tank cleaning machine; designed for demanding cleaning applications where reliability and long service intervals are required.

Quality Standards

The SC 40RT is produced in accordance with ISO 9001 Quality Standards and our certificate of conformity and accreditation is available on request.

Typical applications

- + Ethanol fermenters, storage and process tanks
- + Crude oil storage tanks
- + High density stock chest
- + Large silos and dryers
- + Road tankers and railcars
- + Reactors
- + Large Uni-Tanks
- + Pulp storage tanks



 scanjet



總代理

思沛雅噴霧器材有限公司

22205 新北市深坑區北深路三段270巷8號3樓 TEL. 02-8662-6968 FAX. 02-8662-6967
Website : www.sprayernozzle.com.tw E-mail : sales@sprayernozzle.com.tw

Technical performance

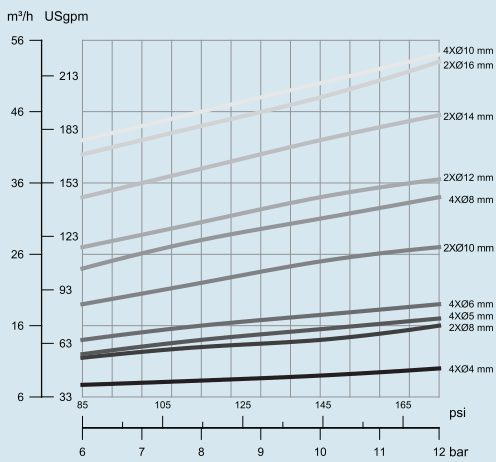

Pressure/Flow

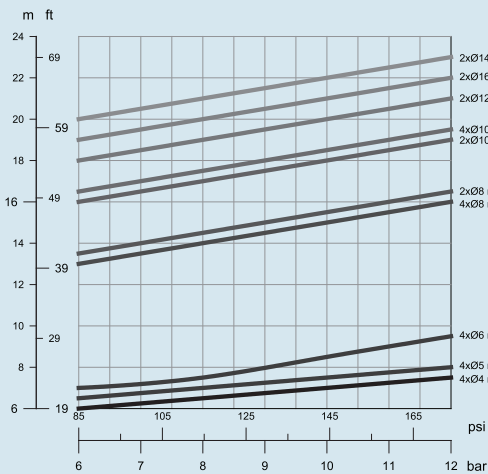

Jet length

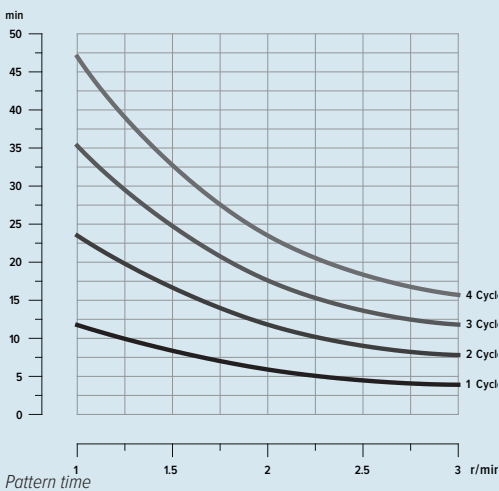

Pattern time

Dimensions

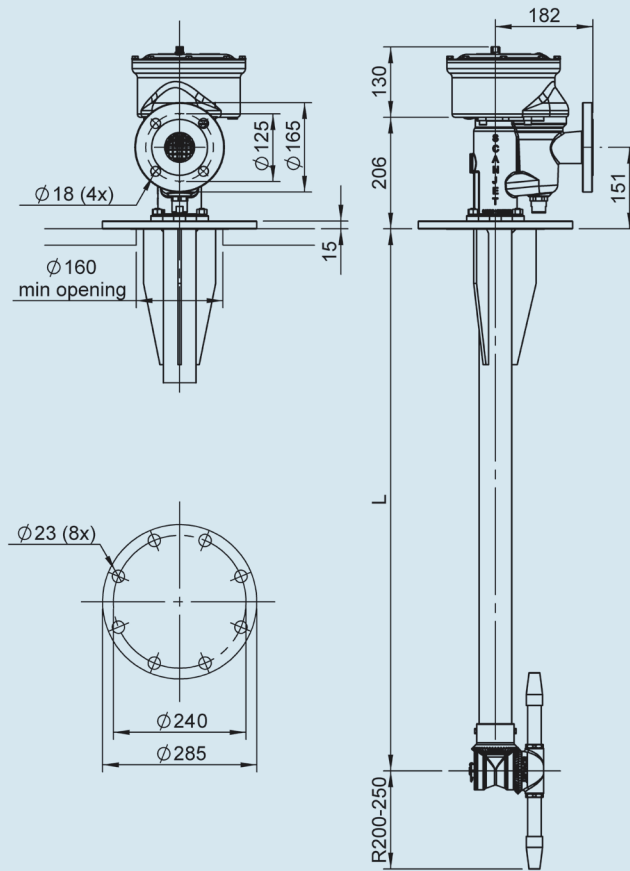

Specifications

| | |
|-----------------------------------|------------------------|
| Flow | 5-55 m ³ /h |
| Inlet pressure | 6-12 bar |
| Max pressure | 14 bar |
| Recommended pressure | 8 bar |
| Max temperature | 95°C |
| Rotation speed | 1-2 rpm |
| Standard length | 1500 mm |
| Weight | 43 kg |
| Per additional meter of main pipe | 10 kg |
| Tank connection | PN16 DN150 |
| Inlet connection | PN16 DN50 |
| Materials | AISI 316, PTFE, Viton |
| Lubrication | Cleaning media |

We reserve the right to changes without prior notice. Issue 2017-03



Scanjet Systems AB
P.O. Box 9316
SE-400 97 Göteborg Sweden
Phone + 46 31 338 75 30
Fax + 46 31 338 75 40
E-mail sales@scanjetsystems.com
Web www.scanjetsystems.com



總代理

思沛雅噴霧器材有限公司

22205 新北市深坑區北深路三段270巷8號3樓 TEL. 02-8662-6968 FAX. 02-8662-6967
Website : www.sprayernozzle.com.tw E-mail : sales@sprayernozzle.com.tw