

SC 45TW

Scanjet tank cleaning equipment

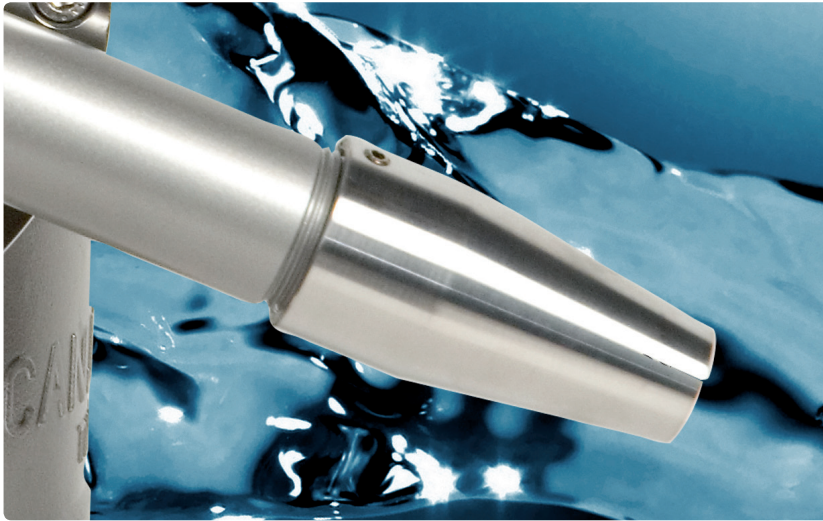

KEY FEATURES

- + Rugged construction
- + Adjustable turbine
- + ISO 9001 Quality
- + Exceptional jet lengths
- + Easy maintenance
- + 316 SS construction
- + Optimized cycle times
- + Flow through gearbox
- + Designed for large tanks

The SC 45TW is a 2" dual nozzle automated tank cleaning machine constructed of 316 stainless steel and other highly corrosion resistant materials. It has a fixed to moving gear ratio of 47 to 49 allowing it to produce a homogenous 360deg pattern that is superior to that of any other rotating jet head in it's class.

The SC 45TW is an integrated turbine class type of tank cleaning machine and employs an adjustable turbine and flow through gearbox. The adjustable turbine allows the rotation speed of the SC 45TW to be adjusted without the need of changing costly stators and/or gearing found in other similar cleaning devices.

Quality Control, Compliances & Certifications

The SC 45TW is produced in accordance with ISO 9001 Quality Standards and our certificate of conformity and accreditation is available on request. Additionally, the SC 45TW conforms to United States ASME standards for construction and others are available upon request.

Typical applications:

- + Crude oil storage tanks
- + Large process vessels and fermenters
- + Large silos and dryers
- + Large reactors
- + Large Uni-Tanks



 scanjet



總代理

思沛雅噴霧器材有限公司

22205 新北市深坑區北深路三段270巷8號3樓 TEL. 02-8662-6968 FAX. 02-8662-6967
Website : www.sprayernozzle.com.tw E-mail : sales@sprayernozzle.com.tw

Technical performance

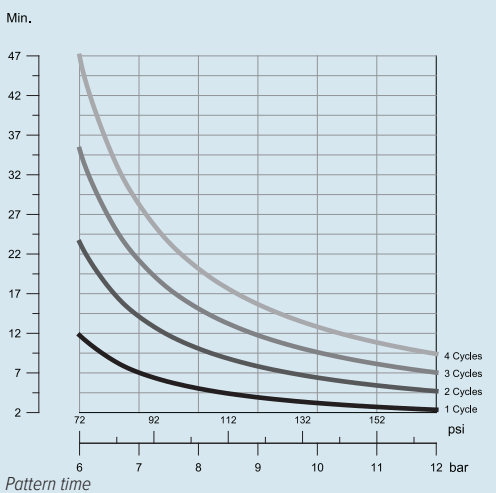
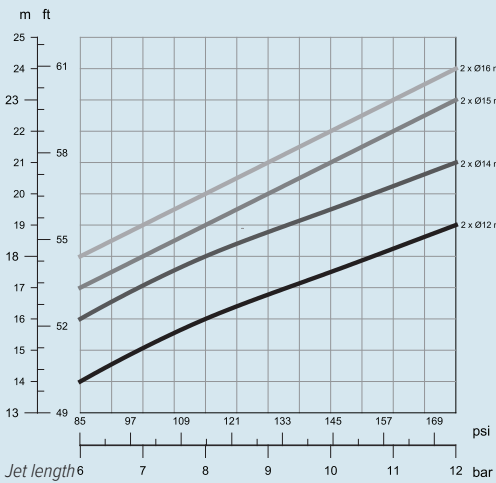
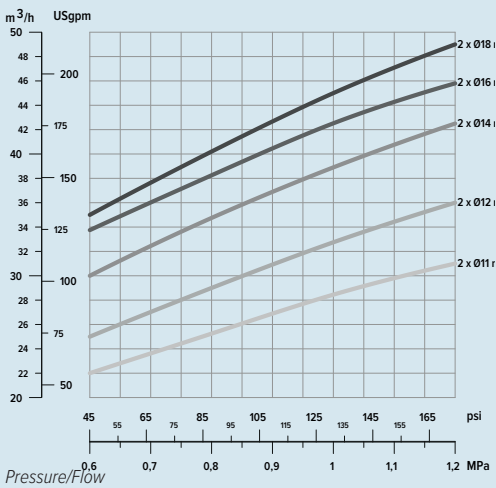

Dimensions

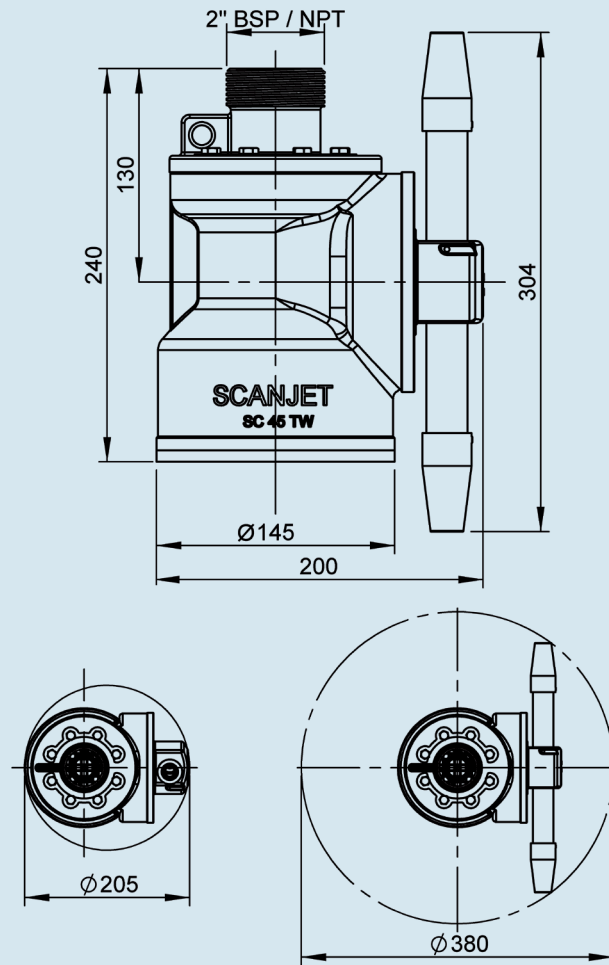

Specifications

Flow	22-48 m^3/h
Inlet pressure	3-10 bar
Max pressure	12 bar
Recommended pressure	6 bar
Max temperature	95°C
Max ambient temperature	140°C
Weight	12 kg
Connections standards	2" BSP/ NPT
Material	AISI 316, PTFE, PEEK
Lubrication	Cleaning media

We reserve the right to changes without prior notice. Issue 2017-03



Scanjet Systems AB
 P.O. Box 9316
 SE-400 97 Göteborg Sweden
 Phone + 46 31 338 75 30
 Fax + 46 31 338 75 40
 E-mail sales@scanjetsystems.com
 Web www.scanjetsystems.com



總代理

思沛雅噴霧器材有限公司

22205 新北市深坑區北深路三段270巷8號3樓 TEL. 02-8662-6968 FAX. 02-8662-6967
 Website : www.sprayernozzle.com.tw E-mail : sales@sprayernozzle.com.tw