

SC 60A

Crude Oil Storage Tank Cleaning Machine



KEY FEATURES

- + Sector Cleaning
- + Support Leg Entry
- + Highly Durable
- + Pneumatic Drive
- + High Solids Loading
- + Stainless Steel Const.
- + Pitch Control
- + Custom Lengths
- + Certified for operation in ATEX zone Zero Environments



Scanjet SC 60A is an advanced tank cleaning nozzle system specifically designed for Crude Oil Storage Tanks where tank entry is limited.

The SC 60A has the ability to make entry into the tank via the support legs on floating roof tanks, as well as other openings that may be available on the tank to be cleaned. It can also be programmed for a specific cleaning pattern.

Sector Cleaning

The SC 60A is pneumatically driven and can be programmed for sector cleaning. If the job requires that the cleaning pattern should only be focused on the tank bottom and 1 meter of the side wall, the SC 60A can perform this function.

Tank Entry

The SC 60A is designed to make tank entry for Crude Oil Storage Tanks as easy as possible. To this purpose, the SC 60A can enter a floating roof storage tank via the support legs affixed to the roof of the tank. Just advise us of the mounting flange type (dimensions) and we will fit the SC 60A to your requirements.

Solids Handling

The SC 60A is a master at handling solids. Crude Oil Tank Cleaning is a dirty and arduous task. Designed to use Crude Oil as the cleaning media. The SC 60A handles solids several times that of conventional machines.

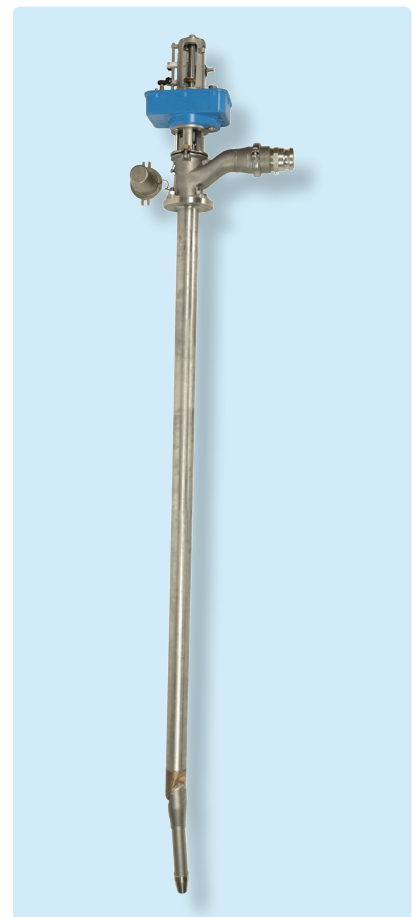

總代理

思沛雅噴霧器材有限公司

22205 新北市深坑區北深路三段270巷8號3樓 TEL. 02-8662-6968 FAX. 02-8662-6967
Website : www.sprayernozzle.com.tw E-mail : sales@sprayernozzle.com.tw

Technical Performance

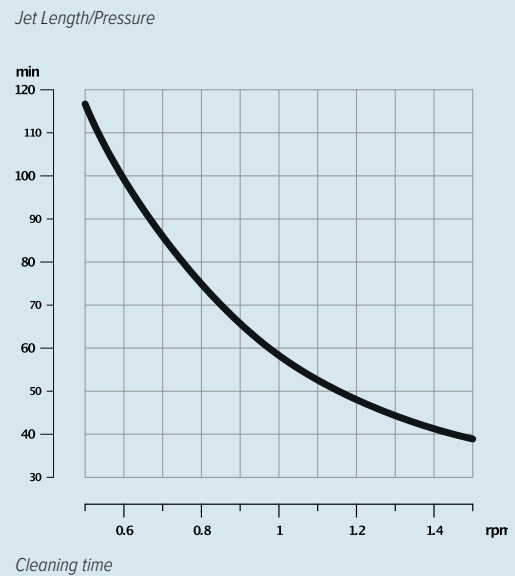
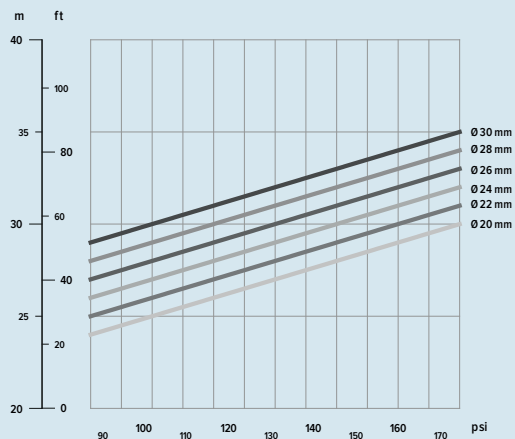
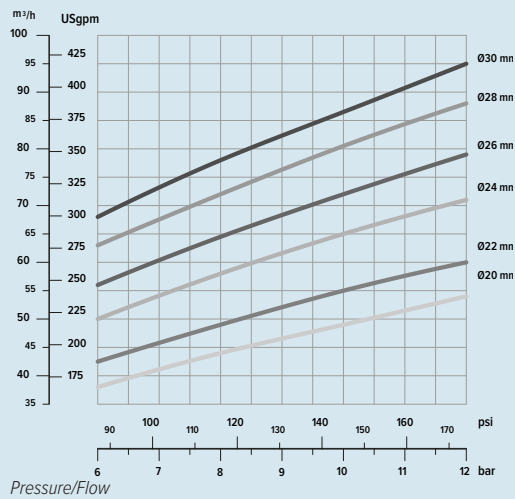

Dimensions

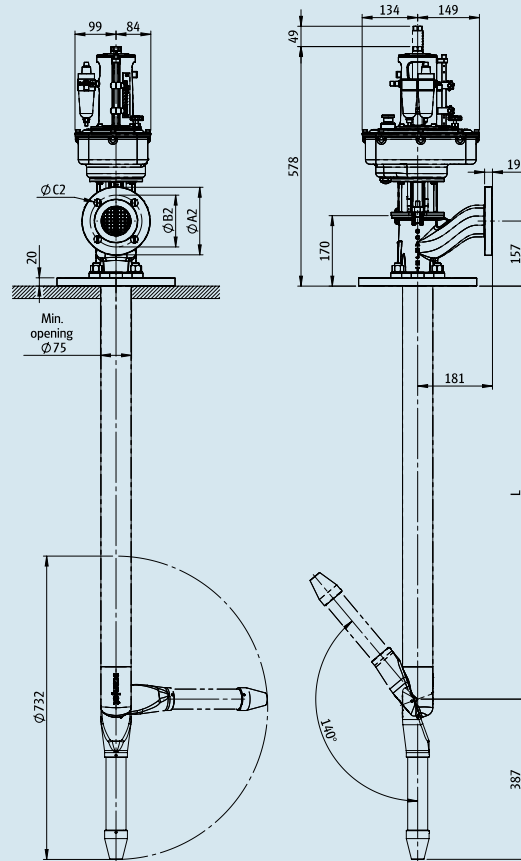

Specifications

Flow	0-96 m³/h
Operating pressure range	0-14 BAR
Max pressure	17 BAR
Recommended pressure	12 BAR
Max temperature	95°C
Standard length	1500 mm
Weight	53 kg
Per additional meter of main pipe	12 kg
Material in contact with cleaning media	AISI 316, PTFE

Drive Unit SC160

Drive Type	Pneumatic
Air Pressure	4-8 BAR
Max Air Consumption	300 liter/minute
Max Cleaning Pattern	140°
Elevation	2.4°
Rotation speed	0.5-1.5 RPM

We reserve the right to changes without prior notice. Issue 2017-03



Scanjet Systems AB
P.O. Box 9316
SE-400 97 Göteborg Sweden
Phone + 46 31 338 75 30
Fax + 46 31 338 75 40
E-mail sales@scanjetsystems.com
Web www.scanjetsystems.com



總代理

思沛雅噴霧器材有限公司

22205 新北市深坑區北深路三段270巷8號3樓 TEL. 02-8662-6968 FAX. 02-8662-6967
Website : www.sprayernozzle.com.tw E-mail : sales@sprayernozzle.com.tw