

# SC 90A

Scanjet tank cleaning equipment



## KEY FEATURES

- + ATEX
- + Programmable sector cleaning
- + Rugged construction
- + External drive
- + High jet impact
- + High capacity

The SC 90A is a single nozzle tank cleaning machine especially developed for sector cleaning tanks/cisterns/vessels in hazardous ATEX classified areas. It gives the user a possibility to optimize the cleaning, with minimal use of time, energy and cleaning media.

SC 90A consists of two main parts; one washing unit that is fixed installed in the tank and one portable air driven drive unit SC150 for operation. The drive units can be exchanged or removed without exposing the tank to the outside atmosphere. It is the product of choice when long jet-lengths and/or a high level of jet impact is required.

### Quality Control, Compliances & Certifications

The SC 90A is produced in accordance with ISO 9001 Quality Standards and our certificate of conformity and accreditation is available on request. Additionally, the SC 90A conforms to United States ASME standards for construction and European, CE and ATEX standards for design, construction and safety.

### Typical applications

- + Crude oil storage tanks
- + Large process vessels and fermenters
- + Large silos and dryers
- + Large reactors
- + Large Uni-Tanks

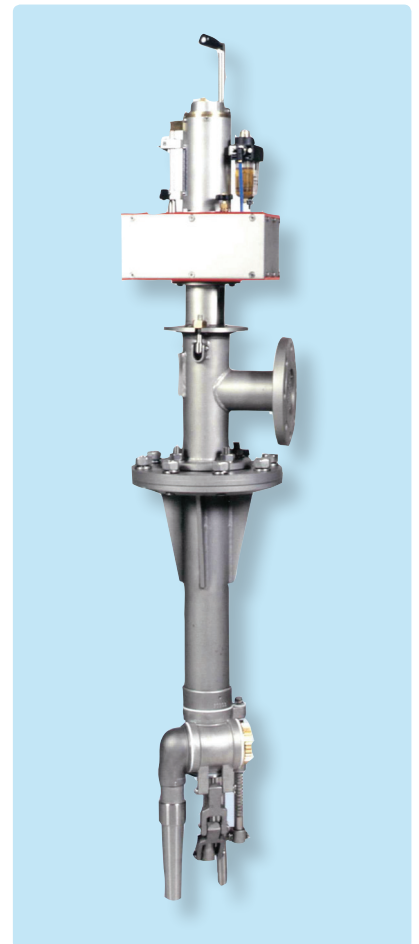

 scanjet



總代理

思沛雅噴霧器材有限公司

22205 新北市深坑區北深路三段270巷8號3樓 TEL. 02-8662-6968 FAX. 02-8662-6967

Website : [www.sprayernozzle.com.tw](http://www.sprayernozzle.com.tw) E-mail : [sales@sprayernozzle.com.tw](mailto:sales@sprayernozzle.com.tw)

## Technical performance

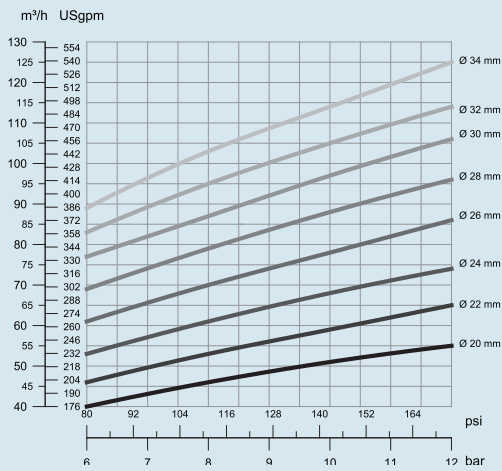

Pressure/Flow

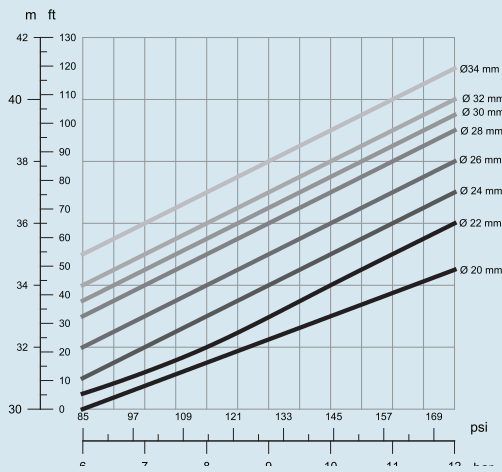

Jet length

## Dimensions

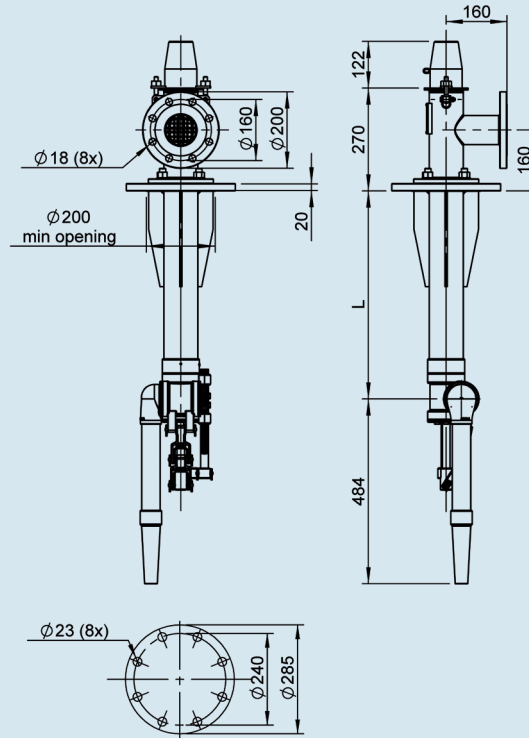

Air pressure	0,5 - 0,7 MPa	0,5 - 0,7 MPa
Air consumption	250 l/min	250 l/min
RPM	0,5 - 2,0	1,0 - 5,0
Elevation per rotation	2°	5°
Sector clean	0 - 180°	0 - 180°

## Specifications

Flow	40-106 m <sup>3</sup> /h
Inlet pressure	6-12 bar
Max pressure	14 bar
Recommended pressure	8 bar
Max temperature	95°C
Rotation speed	0,5-5 rpm
Standard length	1500 mm
Weight	75 kg
Per additional meter of main pipe	15 kg
Tank connection	PN16 DN150
Inlet connection	PN16 DN80
Materials	AlSi 316, PTFE/Viton
Lubrication	Cleaning Media

We reserve the right to changes without prior notice. Issue 2017-03



Scanjet Systems AB  
P.O. Box 9316  
SE-400 97 Göteborg Sweden  
Phone + 46 31 338 75 30  
Fax + 46 31 338 75 40  
E-mail sales@scanjetsystems.com  
Web www.scanjetsystems.com



總代理

思沛雅噴霧器材有限公司

22205 新北市深坑區北深路三段270巷8號3樓 TEL. 02-8662-6968 FAX. 02-8662-6967  
Website : www.sprayernozzle.com.tw E-mail : sales@sprayernozzle.com.tw